

Spare Parts Catalogue

OSSA

250 - **TRIAL**

Mick Andrews Replica

TRIAL

1 SHEET

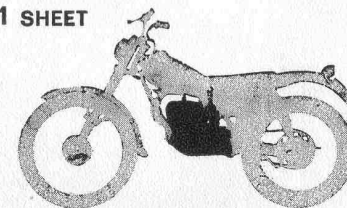

2 SHEET

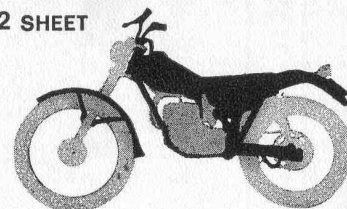

3 SHEET

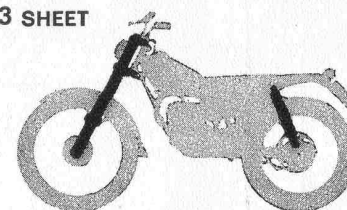

4 SHEET

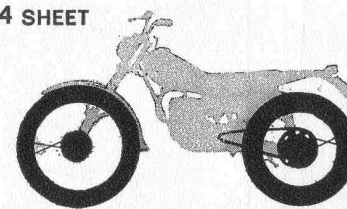

5 SHEET

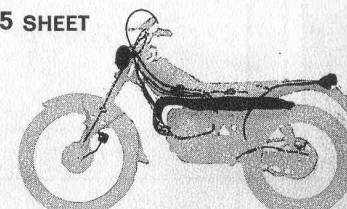

MODEL 250 TR-72		ENGINE						1nd. LIST			
Part Number	DESCRIPTION	Quanti.	Valid from unit n ^{er}	Part Number	DESCRIPTION	Quanti.	Valid from unit n ^{er}	Part Number	DESCRIPTION	Quanti.	Valid from unit n ^{er}
33.176 I-II-IV	Shim washer lay shaft			121.114	Shifting fork shaft	1		991.502	Clutch plate	5	
33.292 I-II-IV-X	Shim washer lay shaft			121.115	Spring selector	1		991.503 CM	Clutch plate	5	
50.404 I-II-IV-X	Shim washer selector	1		121.116	Footshift lever	1		991.512	Plunger clutch arm	1	
50.659	Washer stop bolt kick	1		121.117	Washer 1st. gear	1		991.513	Clutch regulating screw	1	
101.019	Stop bolt kick	1		121.120 M	Needle brg 1st gear	1		991.514	Clutch cam	1	
102.005	Wristpin	1		121.124 M	Selector body assembly	1		991.516 M	Chain primary	1	
111.004 MI	Connecting rod assembly	1		121.125	Dust cover selector shaft	2		991.605	Locating dowel engine cases	1	
111.004 S-20 MI	Connecting rod assembly oversize			121.126	Plug selector shaft	1		991.606	Flywheel clutch side, 1st. oversize	1	
111.004	Connectin rod	1		121.127 M	Selector shaft assembly	1		991.607	Gasket clutch cover	1	
111.009	Cylinder gasket	1		121.128	Washer selector shaft spring	1		991.608	Anchor pin	1	
111.010 M	Crankshaft assembly	1		121.141	Gear 2nd. mainshaft	1		991.609	Inspection cover	1	
111.010	Flywheel clutch side	1		121.142	Gear 3rd. mainshaft	1		991.610	Inspection cover gasket	1	
111.010 S-20	Flywheel clutch side 1st. oversize	1		121.144	Gear 5th. mainshaft	1		991.611	Grommet rubber	1	
111.011	Flywheel magneto side	1		121.146	Layshaft	1		991.612 B	Tube breather	1	
111.011 S-20	Flywheel magneto side 1st. oversize	1		121.147	Gear 1st. layshaft	1		991.615	Screw engine cover primary side	1	
111.016	Spacer intake manifold	1		121.148	Gear 2nd. layshaft	1		991.701	Ratchet kickstarter	1	
111.017	Stud. acrburettor	2		121.149	Gear 3nd. layshaft	1		991.703	Spring	1	
111.018	Stud. cylinder head	4		121.175	Shaft kickstarter	1		991.704	Washer kickstarter spring	2	
111.019	Nut, intake manifold	2		121.200 M	Engine cases assembly	1		991.706	Circlip kickstarter shaft	1	
111.076	Thrust washer	1		121.202	Clutch cover	1		991.707	Stop kickstarter spring	1	
111.077	Spacer	1		121.203 B	Magneto cover	1		991.708	Spring kickstarter engage	1	
111.078 M	Needle bearing	1		121.206	Bushing	2		991.709	Thrust washer kickstarter shaft	1	
111.079	«O» ring	1		122.016 MI	Carburettor	1		991.710	Thrust washer kickstarter gear	1	
111.080 BM	Clutch hub assembly	1		122.025 MI	Magneto assembly	1		991.717	Spring, lever pin	1	
111.081	Clutch plate inner	1		122.030 MI	Spark plug	1		991.718	Pin, kick lever	1	
111.082 M	Clutch plate outer	1		122.177 MI	Kickstarter lever assembly	1					
111.083 M	Clutch hub assembly	1		122.177	Kickstarter lever	1					
111.085	Cup clutch spring	5		911.131	Nut cylinder head	4					
111.086	Clutch spring	5		911.139 II-IV-X	Shim washer	1					
112.112	Countershaft sprocket	1		911.246	Rubber footshift lever	1					
112.116 M	Needle bearing cage 5 th. gear	2		911.514 B	Slotted nut clutch spring	5					
112.175	Kickstarter driving gear	1		911.604	Drain plug	1					
112.181 B	Kick lever support	1		911.609 C	Locating dowel	4					
112.182	Support kick lever ring	1		911.611	Bolt engine cases	15					
112.183	Spring washer lever	1		911.614	Screw	4					
114.008	Cage big end bearing	1		911.617	Gasket drain plug	1					
114.009	Roller big end bearing	14		912.604	Washer selector shaft	1		AB-80	Washer engine case	1	
114.081	Nut magneto flywheel	1		921.111	Shim washer mainshaft 0,05	1		ACF-60	Washer oil level screw	1	
116.033	Intake manifold	1		921.112	Shim washer mainshaft 0,1	1		AF-150	Washer magneto	1	
118.051 M	Cylinder assembly	1		921.113	Shim washer mainshaft 0,2	1		AG-60	Lock washer clutch arm, inspection cover	3	
118.051 S-20 M	Cylinder assembly 1st. oversize	1		921.617	Washer	1		AG-160	Washer cush drive hub	2	
118.052	Cylinder sleeve	1		941.205	Circlip	5		AN-120	Flat washer	1	
118.053 MI	Piston assembly	1		941.209	Spacer countershaft sprocket	1		ASE-100	Snap ring fork shaft	2	
118.053 S-20 MI	Piston assembly 1st. oversize	1		941.212	Washer countershaft sprocket	1		ASE-140	Snap ring selector	1	
118.053 S-40 MI	Piston assembly 2nd. oversize	1		942.167	Nut stop bolt	1		ASE-180	Snap ring selector and kickstarter	2	
118.053 S-60 MI	Piston assembly 3rd. oversize	1		991.105 M	Rod brg. cage	1		AT-60	Clutch arm washer	1	
118.053	Piston	1		991.107 B	Crankshaft pin	1		AT-70	Carburettor mounting washer	2	
118.053 S-20	Piston 1st. oversize	1		991.107 B S-20	Crankshaft pin 1st. oversize	1		AT-80	Washer head and engine case	5	
118.053 S-40	Piston 2nd. oversize	1		991.109 B	Piston circlip	2		B-555	Clutch rod ball	1	
118.053 S-60	Piston 3rd. oversize	1		991.112	Engine sprocket	1		CA-10.015	Clutch bolt cotter pin	5	
118.054	Piston ring	2		991.119	Shaft cush drive	1		CE-30.022	Kick support pin	1	
118.054 S-20	Piston ring 1st. oversize	2		991.120	Coupling cush drive	1		FE-60	Clutch arm nut	1	
118.054 S-40	Piston ring 2nd. oversize	2		991.121	Stop spring	1		FE-80	Nut clutch and engine case	2	
118.054 S-60	Piston ring 3rd. oversize	2		991.122	Spring cush drive	1		KC-17-47-14	Gearbox bearing	1	
118.057	Cylinder head	1		991.123	Allen nut, cush drive	1		KC-25-52-15	Gearbox bearing	1	
118.059	Head gasket	1		991.139 II-IV-X	Shim washer	1		SG-25-42-8-DL	Oil seal	2	
118.068	Compression release plug	1		991.140	Right main brg.	1		SG-29-40-7-DL	Oil seal	1	
118.069	Compression release gasket	1		991.141	Left main brg.	1		SO-139-26	«O» ring selector shaft	1	
121.077	Nut clutch hub	1		991.211	Selector fork	1		SO-178-26	«O» ring kickstarter	2	
121.078	Clutch rod	2		991.214	Nut countershaft sprocket	1		TE-60.020	Bolt gear lever	1	
121.079 M	Clutch arm assembly	1		991.215	Spring stop selector	2		TE-70.025	Bolt kickstarter lever	1	
121.100	Main shaft	1		991.216	Oil seal	1		TE-80.040	Engine bolt	1	
121.103	Gear 4 th main shaft	1		991.228	Spring	1		TL-50.015	Screw magneto back plate	3	
121.105	Dog wheel 4 th. and 5 th. gear	1		991.229	Guide selector	1		TL-60.012	Clutch, cover and oil level bolt	3	
121.110	Shifting fork 2nd.	1		991.231	Anchor pin selector	1		TS-60.022	Engine case bolt	2	
121.111	Sniffing fork 1st. and 3rd	1		991.232	Spring	1		TS-60.075	Bolt magneto cover	2	
121.112	Shiftingfork 4th. and 5 th	1		991.234	Washer selector shaft	1		TS-60.080	Bolt magneto cover	1	
121.113	Spacer 5th gear	1		991.235	Retaining ring	1		XR-30.013	Magneto key	1	

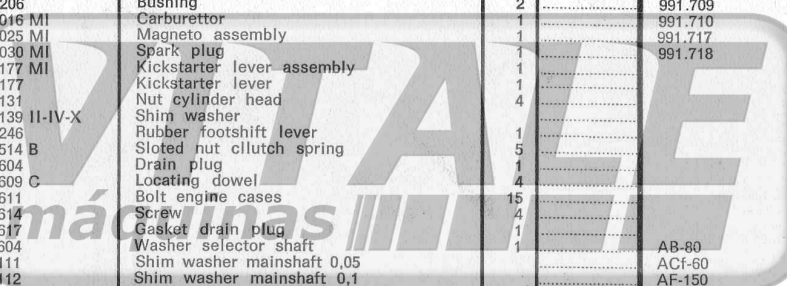

COMMON PARTS

EDITION			
1			
11-71			

MODEL 250 TR-72		FRAME										2nd. LIST	
Part Number	DESCRIPTION	Quanti.	Valid from unit n°r	Part Number	DESCRIPTION	Quanti.	Valid from unit n°r	Part Number	DESCRIPTION	Quanti.	Valid from unit n°r		
13.714	Washer rear number plate	2		122.730	Rubber rest gas tank	1							
80.574	Nut, brake pedal	1		122.746 Ml	Braket	1							
112.336	Bolt, brake chain guide	1		122.750	Chain guard	1							
112.400 Cd	Right footpeg	1		122.770	Air filter protection (inner)	1		AB-70	Spring washer	6			
112.400 Ci	Left footpeg	1		122.770 M	Air filter protection (outer)	1		AB-80	Spring washer	2			
112.402 B	Footpeg shaft	2		122.772	Spring air filter	1		AB-100	Spring washer	2			
112.471	Swing arm axle	1		122.774	Filter	1		AG-60	Washer rear and front fenders	15			
112.472	Bushing swing arm	2		122.775	Plastil tube air filter and carburettor	1		AG-80	Washer bracket chain guide	1			
112.492	Plug swing arm	1						AN-60	Washer plastic shells and cover filter	7			
112.709	Rear number plate	1		122.776	Filter clamp	2		AN-120	asher petcock assy	1			
112.725	Fuel line	1		122.780 bL	Right shell	1		ASt-90/100	Circlip	1			
112.745 bl	Number plate	1		122.781 bL	Left shell	1		AT-60	Washer fenders, shell and seat	12			
112.830	Handlebar	1		122.782 Mng	Bracket air filter	1			Washer engine, chain guide and chain guard	8			
118.318	Specifications label	1		122.783 Mng	Air filter cover	1		AT-80	Engine washer	2			
118.507	Washer handlebar bolt	4		122.784	Mick Andrews decal	2		AT-100	Swing arm washer	2			
118.725	Tank badge OSSA	2		122.820 M	Brake lever assembly	1		AT-120	Cotter pin brake arm	2			
118.726	Bolt tank badge	4		122.822 M	Brake lever assembly	1		CA-20.020	Cotter pin tensioner	2			
118.820	Handlebar mount	2		122.824	Left bushing	1		CA-20.025	Cotter pin	1			
118.821	Handlebar clamp	2		122.825 M	Chain tensioner arm	1		CE-50.024	Nut, fenders, cover filter and number plate	17			
118.822	Bolt handlebar	4		122.827	Washer chain tensioner	2		FE-60	Nut	6			
121.320	Bolt engine	2		122.828	Spring chain tensioner	1			Nut engine mount and chain guide	3			
121.720	Clip fuel line	4		122.830	Spring rear brake	1		FE-70	Nut rear engine mount	2			
121.826 Ml	Twist grip assembly	1		122.833	Chain tensioner	1		FE-80	Bolt engine protector	8			
122.300 M	Frame assembly	1		122.834	Side stop (chain)	1		FE-100	Bolt rear fender	1			
122.330	Skid plate	1		122.835	Spring chain tensioner	1		TA-70.020	Bolt seat	2			
122.333	Reinforcement skid plate	4		122.836	Right brake bushing	1		TE-60.012	Bolt number plate	2			
122.334 d	Right mount skid plate	1		122.837	Washer brake shaft	1		TE-60.015	Bolt front fender	7			
122.334 i	Left mount skid plate	1		122.900 M	Seat	1		TE-60.020	Bolt front fender and speedometer mount	3			
122.335	Nut skid plate mount	1		123.340	Bolt engine	2		TE-60.022	Bolt chain guard	1			
122.425 M	Side stand	1		124.831 Ml	Clutch lever assembly	1		TE-60.035	Bolt shell	3			
122.429	Side stand shaft	1		124.832 Ml	Front brake lever	1		TE-80.015	Bolt shell	4			
122.430	Spring side stand	1		912.604	Washer brake pedal	2		TL-60.012	Nut handlever bolt	1			
122.450 M	Swing arm assembly	1		918.118 M	Petcock assy.	1		TL-60.018	Adjusting bolt	2			
122.458 M	Bracket chain guide	1		918.231	Nut footpeg	1		A-18/053	Locknut adjusting bolt	2			
122.473	Bolt bracket chain guide	1		924.506	Washer, rear fender and number plate	7		A-18/838	Brake lever mount	1			
122.474	Bolt swing arm	1						A-18/839	Brake lever	1			
122.700 M	Front fender	1		948.220	Tube breather	1		A-534/001	Clutch lever	1			
122.705 M	Rear fender	1		948.221	Fuel line	1		A-534/002	Clutch lever mount	1			
122.706	Bolt rear fender	2		958.010	Washer brake lever	1		A-534/003	Bolt clutch and brake levers	2			
122.707	Washer rear fender and tail light	2		997.107	Rubber grip throttle	1		A-534/004	Bolt clutch and brake lever mount	4			
122.720 Mbl	Gas tank assembly	1		997.108	Rubber grip handlebar	1		A-534/005					
122.723	Gas cap	1		998.220	Rubber seal	1		A-534/006					
122.725	Gasket gas tank-seat	1											
122.727	Rubber washer gas tank	2											

EDITION

1				
11-71				

**MODEL
250 TR-72**

SUSPENSION UNITS

3th. LIST

Part Number	DESCRIPTION	Quanti.	Valid from unit n°r	Part Number	DESCRIPTION	Quanti.	Valid from unit n°r	Part Number	DESCRIPTION	Quanti.	Valid from unit n°r
13.714	Washer shock absorbers	4		LI-1505-37	Top silentblock	4		LI-8101-15	Allen bolt M8 x 60	2	
112.511	Nut, steering shaft	1		LI-1513-10	Inner tube	4		LI-8101-25	Bolt	2	
112.517 B	Nut, steering adjuster	1		LI-1514-02	Oil tank	2		LI-8101-27	Allen bolt M8 x 25	2	
112.518	Felt washer	2		LI-1514-04	Damper assembly	2		LI-8102-11	Nut 8 x 1,25	—	
112.519	Dust cover	2		LI-1514-011	Regulating bushing	2		LI-8103-10	Polished washer	4	
118.505	Bolt stanchion tube	8		LI-1514-35	Top grip	2		LI-8104-10	Spring washer	2	
118.506	Bolt steering shaft bolt	1		LI-1514-47B	Spring	2		LI-8104-16	Spring asher	—	
118.507	Washer stanchion tube bolt	8		LI-1514-86	Housing for spring	4		LI-8105-12	Bottom nut	2	
118.508	Washer steering shaft bolt	1		LI-1532-36	Silentblock housing	2		LI-8110-10	«O» ring	2	
122.521	Top yoke	1		LI-6204-07A	Valve and tube assembly	2		LI-8110-11A	«O» ring	2	
122.522 M	Bottom yoke with stem	1		LI-6204-015	Valve assembly	2		LI-8110-12	«O» ring E-16	2	
122.540 MI	Suspension assembly right	1		LI-6204-20	«O» Ring	2		LI-8111-10	Ball Ø 3,5	2	
122.541 MI	Suspension assembly left	1		LI-6204-23	Stop spring	2		LI-8113-10	Oil seal 35 x 47 x 7	4	
122.542 MI	Shock absorber assembly	2		LI-6204-29	Valve	2		LI-8114-10	«O» ring 26 x 32 x 3	2	
914.263	Washer	2		LI-6204-78	Plunger	2		LI-8114-11	«O» ring 12 x 17 x 2,5	2	
				LI-6204-98	Cylinder valve support	2		LI-8114-21	«O» ring	2	
				LI-6204-105-1	Washer valve	2		LI-8115-11	«O» ring 9 x 16 x 1,5	2	
	COMMON PARTS			LI-6204-110	Washer valve bolt	2		LI-8116-10	Fibre washer 65 x 12 x 1,5	2	
				LI-6208-96	Dust cover	2		LI-8118-32	Top	2	
KR-20-47-14	Ball bearing assembly	2		LI-6215-029	Stanchion plug assembly	2		N-1027	Valve assembly	2	
TE-60.012	Bolt shock absorber	4		LI-6215-107	Spring stanchion tube	2		R-1557	Spare parts kit	1	
				LI-6215-125	Stanchion plug	2					
LI-1101-11	Spring, seal	2		LI-6215-179	Bolt, stanchion plug	2					
LI-1101-12 A	Spring guide	2		LI-6269-018	Right tank assembly	1					
LI-1201-13	Washer spring oil seal	2		LI-6269-019	Left tank assembly	1					
LI-1501-15	Oil seal	2		LI-6269-22	Stanchion tube 535 mm.	2					
LI-1501-16	Adjusting plug	2		LI-6269-47	Spring	2					
LI-1501-26	Guide	2		LI-6269-127	Right tank	1					
LI-1501-37	Bottom silentblock	4		LI-6269-129	Left tank	1					

EDITION

1				
11-71				

EDITION			
1			
11-71			

SUSPENSION UNITS

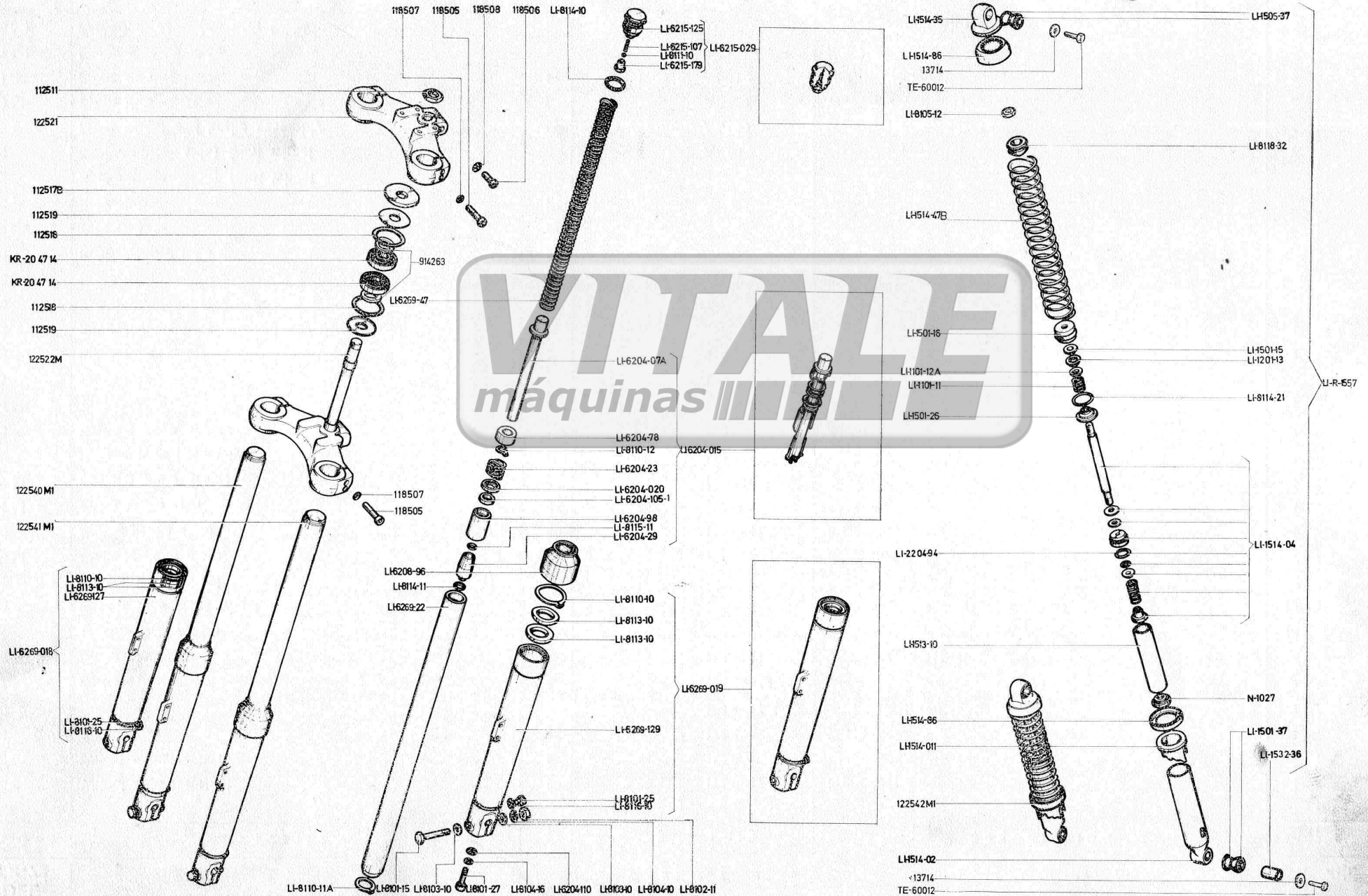
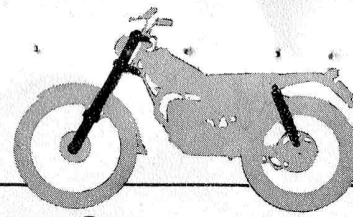

MODEL
250 TR-72

WHEELS

4th. LIST

Part Number	DESCRIPTION	Quantity	Valid from unit n ^{er}	Part Number	DESCRIPTION	Quantity	Valid from unit n ^{er}
105.460 d	Wheel adjuster right	1		122.630 MI	Front hub assembly	1	
105.460 i	Wheel adjuster left	1		122.640	Hub reinforcement	12	
105.604	Aligning spacer tube	4		122.646	Reem	1	
105.606	Dust cover	4		122.650 MI	Rear wheel and brake assembly	1	
105.607	Felt washer	4		122.650 M	Rear hub	1	
105.619	Brake cam	2		122.653	Bolt rear sprocket	4	
105.621	Washer brake cam	2		122.654	Spokes (inner side) rear wheel	18	
106.603	Spacer tube front wheel	1		122.655	Spokes (outer side) rear wheel	18	
106.604	Spacer front wheel	1		122.656	Sprocket bushing	4	
106.609 M	Front backing plate	1		122.657	Rear sprocket	1	
106.610	Spring brake shoe	4		122.658 MI	Secondary chain	1	
106.611 M	Front brake cam	2		122.660	Rear axle	1	
106.657 M	Backing plate (rear)	1		122.661	Spacer	1	
106.659	Spacer tube assembly	1		122.664	Lock nut	1	
112.608	Backing plate spacer	1		122.666	Reem	1	
112.614 MI	Tyre dog	2		122.680 MI	Rear hub and brake assembly	1	
112.631	Front tyre	1		122.690 MI	Rear hub assembly	1	
112.632	Inner tube	1		914.367	Nut front axle	1	
112.633	Rubber inner tube	1		936.104 MI	Speedo drive assembly	1	
112.638	Spoke nipples	72					
112.658	Inner tube	1					
112.659	Rubber inner tube	1					
112.664 MI	Tyre dog	1					
112.670	Rear tyre	1					
121.605	Spoke (inner side) front wheel	18					
121.606	Spoke (outer side) front wheel	18					
122.600 MI	Front wheel and brake assembly	1		AT-80	Brake cam washer	2	
122.600 M	Front Hub	1		AT-100	Washer rear sprocket	4	
122.601	Front axle	1		AT-120	Washer wheel axle	3	
122.607 MI	Leading brake shoe	4		FE-80	Nut, brake cam	2	
122.620 MI	Front hub assembly with brake	1		FE-120	Nut rear axle	2	
				KC-12-32-10-RS	Wheel bearing with dust cover	5	
					COMMON PARTS		

EDITION

1				
11-71				

PRINTED IN SPAIN

WHEELS

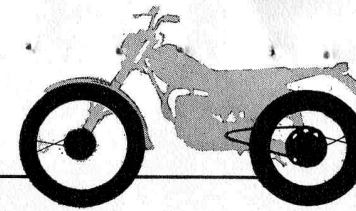

250 TR-72

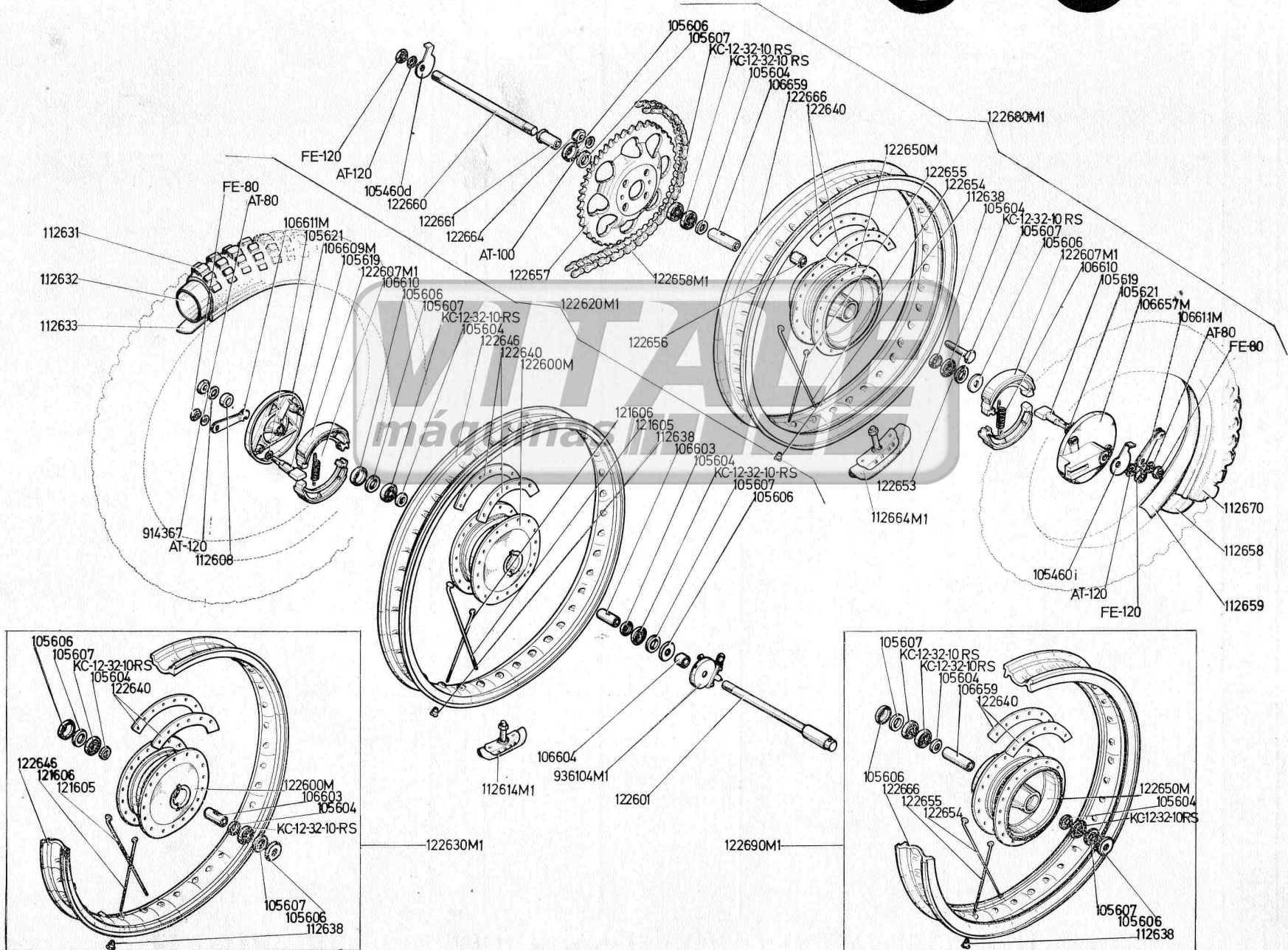

MODEL 250 TR-72		ELECTRICAL ASSEMBLY AND EXHAUST COMPONENTS					5th. LIST	
Part Number	DESCRIPTION	Quantity	Valid from unit n ^{er}	Part Number	DESCRIPTION	Quantity	Valid from unit n ^{er}	
112.813 M	Horn	1		124.820	Clip cable guide	1		
112.936	Spring auxiliary muffler	1		953.313	Nut brake lever (left and)	1		
114.846 BMI	H. T. coil	1		957.408 MI	Junction box	1		
118.844 B	Cable guide	1		996.008 MI	Junction box	1		
121.802 MI	Head light assembly	1		998.303 B	Gasket exhaust pipe	1		
121.803	Spark plug cap	1		998.312 MI	Muffler clamp	1		
121.804	Spring spark plug cap	1						
121.842-M	Clutch cable assembly	1						
122.116	Shift lever (right hand)	1						
122.807 M	Wiring harness (Stop light and tail light)	1		919.102	Spark plug socket	1		
122.808	Head light bracket	2		919.105	Adjustable wrench 6 mm.	1		
122.809	Speedometer bracket	1		919.108	Pliers	1		
122.810	Adjusting plate	2		919.109	Tool bag	1		
122.811	Adjusting plate	2						
122.812	Spacer head light	1						
122.813	Spacer speedometer	1						
122.815 MI	Tail light	1						
122.816	Tail light mount	1						
122.817 MI	Wiring head light with switch box	1		AG-40	Washer, horn mount	2		
122.818 M	Wiring harness	1		AG-60	Washer H. T. coil and cable guide	3		
122.819 M	Ground wiring tail light	1		AG-80	Washer muffler assembly	1		
122.829 MI	Ground wiring speedometer	1		AG-100	Washer brake lever (left and)	1		
122.831 MI	Speedometer	1		AT-40	Washer horn	2		
122.838 M	Brake lever (Left hand)	1		AT-60	Washer H. T. coil	2		
122.840	Brake shaft (left hand)	1		AT-80	Washer exhaust pipe	1		
122.853 M	Rear brake cable assembly	1		FE-40	Nut horn	2		
122.854 M	Front brake cable assembly	1		FE-60	Nut H. T. coil	2		
122.855 M	Thottle cable assembly	1		LC-6-15 Ø 15	Stop bulb	1		
122.920	Exhaust pipe nut	1		LC-6-5 Ø 10	Tail light bulb	1		
122.921	Exhaust pipe nut	1		Lp-6-30/30 Ø 20	Head light bulb	1		
122.922 M	Muffler assembly	1		P-60	Rubber protector wiring harness	3		
122.940 M	Auxiliary muffler assembly	1		TE-60.010	Bolt cable guide	1		
				TE-60.015	Bolt H. T. coil	2		
				TE-80.020	Bolt muffler assembly	1		
				TL-40.012	Bolt horn mount	2		

TOOLS

COMMON PARTS

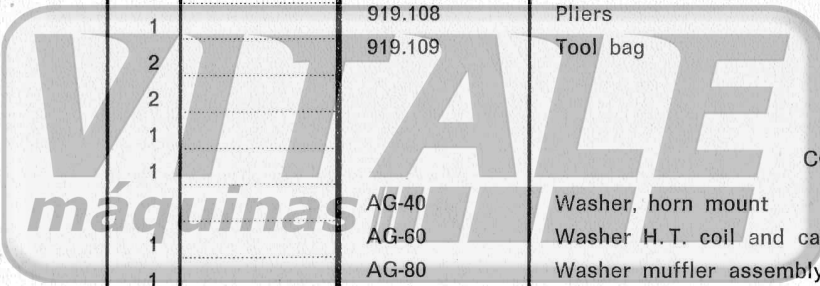

EDITION				
1				
11-71				

EDITION			
1			
11-71			

ELECTRICAL ASSEMBLY AND EXHAUST COMPONENTS

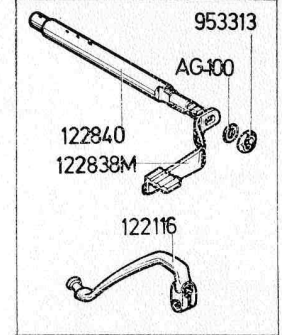
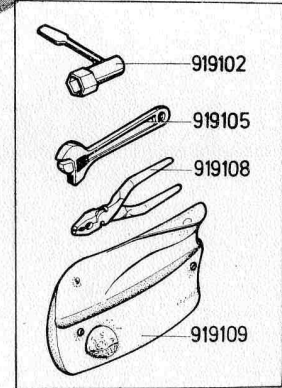
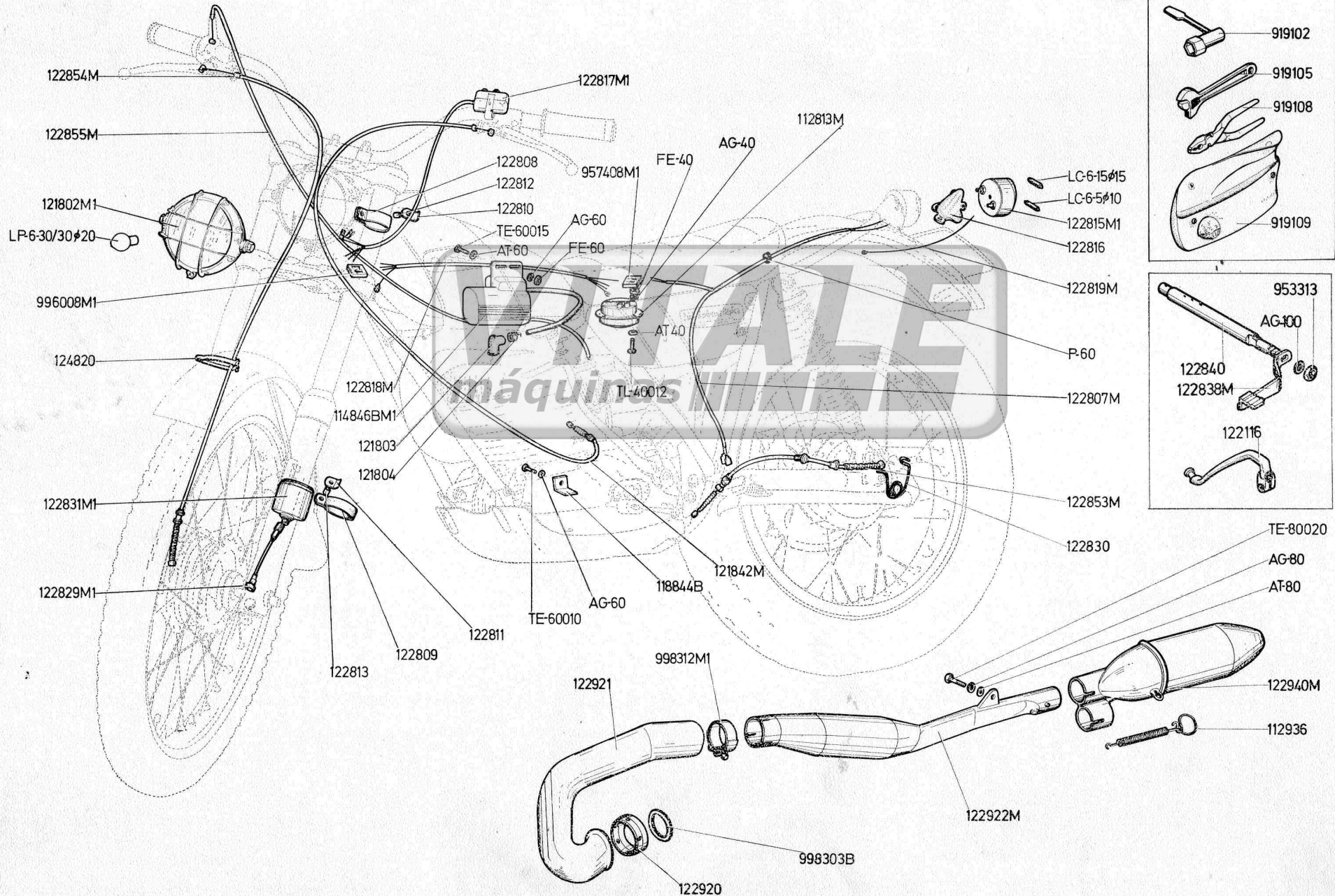
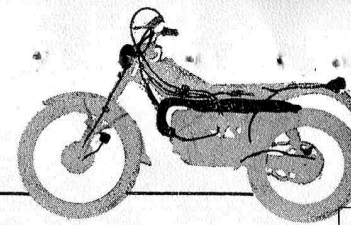

EDITION			
1			
11-71			

PARTS LIST FOR 250 TRI - 250 TRA - DIFFER FROM 250 TR - 72

TRI-72

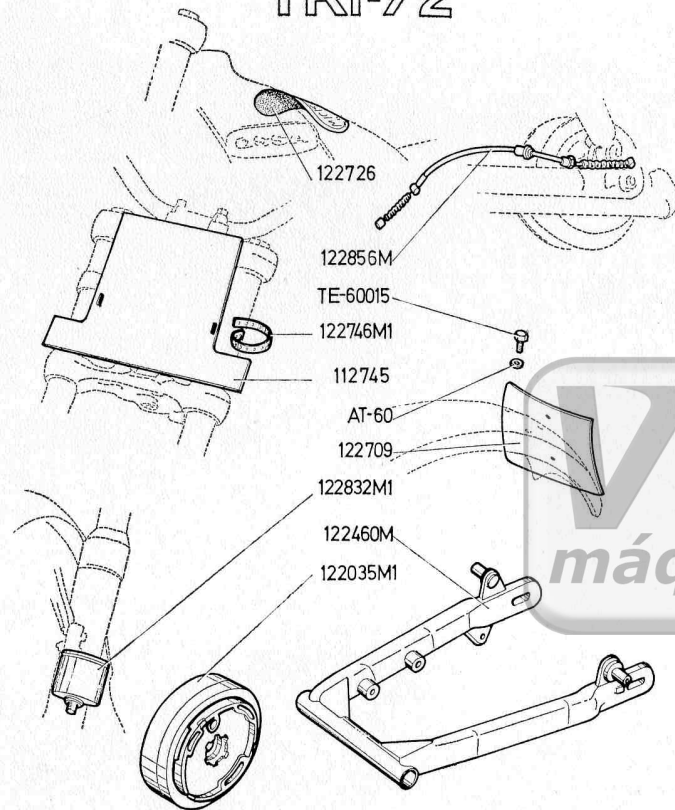

TRA-72

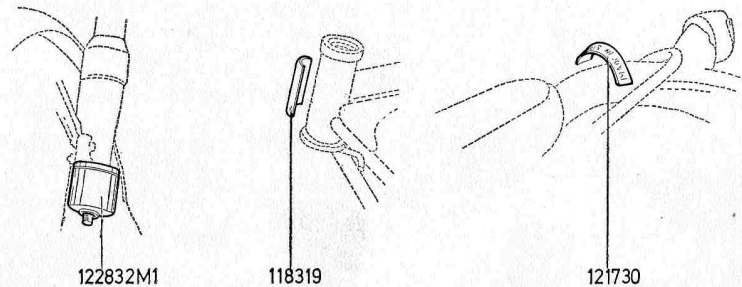

250 TRI ENGINE

122.035 MI Flywheel magneto; substitutes 122.025 MI

FRAME

122.460 M Swing arm; substitutes 122.450 M

122.709 Rear number plate; substitutes 112.709

122.745 Number plate

122.746 MI Clamp number plate

122.726 Decal «Mick Andrews Replica»

TE-60015 Bolt rear fender substitutes 122.706

AT-60 Washer rear fender substitutes 122.707

ELECTRICAL ASSEMBLY

122.856 M Rear brake cable substitutes 122.853 M

122.832 MI Mile counter; substitutes 122.831 MI

250 TRA FRAME

118.319 Identification label; substitutes 118.319

121.730 Decal «Made in Spain»

ELECTRICAL ASSEMBLY

122.832 MI Mile counter; substitutes 122.831 MI