

 **OSSA**

pioneer

ENDURO

máquinas

175 AE-

Spare Parts Catalogue

70

MODEL 175 AE-70		FRAME										2nd. LIST	
Part Number	DESCRIPTION	Quanti.	Valid from unit n°r	Part Number	DESCRIPTION	Quanti.	Valid from unit n°r	Part Number	DESCRIPTION	Quanti.	Valid from unit n°r		
13.714	Washer, engine protector, rear fender, gas tank	12		118.701	Front fender mount	1		992.304	Clevis pin rear brake	1			
101.457	Bolt rear wheel adjuster	2		118.705 M (*)	Fender rear	1		992.307	Brake pedal return spring	1			
101.826 MI	Throttle assembly	1		118.720 BM (*)	Gas tank	1		992.355	Side stand spring	1			
111.762	«24 Horas» decal	1		118.724	Tube breather	1		992.356 B	Clevis pin, center stand	1			
112.300 DM	Frame assembly 250 cc	1		118.725	Tank badge OSSA	2		994.208	Swing arm shaft	1			
112.319	Bolt engine	1		118.726	Bolt tank badge	4							
112.320	Bolt engine and chain guide	3		118.727	Rubber washer tank mount	2							
112.321	Engine protector	1		118.728	Rubber rest. gas tank	1							
112.400 Cd	Right front foot peg	1		118.743	Decal 250 cc	1							
112.400 Ci	Left front foot peg	1		118.745	Decal 175 cc	1		AB-80	Spring washer	4			
112.402 B	Foot peg shaft	2		118.765 M	Tool box cover	1		AG-60	Washer engine protector, and fenders	12			
112.425 BM	Center stand assembly	1		118.766	Mount tools box cover	2							
112.450 BM	Swing arm	1		118.770 BM	Air filter protector 250 cc	1		AN-60	Washer plastic shell	4			
112.460 M	Rubber bushing swing arm	2		118.776 M	Air filter protector 175 cc	1		AN-120	Washer petcock	2			
112.461	Spacer tube swing arm	1		118.780 M	Plastic shell	1		AN-140	Washer rear brake pedal	1			
112.473	Bolt, chain guide	2		118.818 M	Handlebar	1		ASL-90/100	Washer rear fender brace	1			
112.485	Spacer chain guide	1		118.820	Mount handlebar	2		AT-60	Washer fenders shell and seat	12			
112.486	Pin chain guide	1		118.821	Handlebar clamp	2		AT-80	Washer engine, chain guide, fenders and chain guard	11			
112.725	Fuel line right	1		118.822	Bolt, handlebar	2		AT-120	Washer passenger foot pegs and arm shaft	2			
112.726 B	Fuel line left	1		118.841	Regulation lappel (Handlebar)	4							
112.750	Chain guard	1		118.845	Spark plug lappel (Handlebar)	1		CA-20015	Cotter pin brake arm	1			
112.762	Enduro decal	1		118.900 M	Seat	1		FE-60	Nut fenders and shell	10			
112.800 B	Brake pedal	1		118.902 M (*)	Seat mount	1		FE-70	Nut adjusting bolt	2			
112.829 dM	Right cables dust protector	1		118.904	Gasket Seat mount	1		FE-80	Nut engine mount, chain guide, and rear fender	7			
112.829 iM	Left cables dust protector	1		913.362 C	Spacer tube	2		FE-120	Swing arm shaft nut and passenger foot peg	1			
112.905	Seat nut	2		917.206 B	Rubber grip throttle	2							
114.770	Made in Spain decal	1		917.207 B	Rubber grip handlebar	1		TE-60015	Bolt engine protector, gas tank and shell	8			
114.830 MI	Clutch lever assembly	1		918.118 M	Petcock assembly	2							
114.831 MI	Brake lever assembly	1		918.214 B	Gas cap	1		TE-60025	Bolt rear fender	4			
117.400 MI	Passenger foot peg	2		918.215 B	Rubber seal	1		TE-60042	Bolt front fender	4			
118.310 BM	Frame assembly 175 cc.	1		918.231	Footpeg nut	2		TE-70028	Bolt brake pedal	1			
118.318	Specifications lappel (Frame)	1		932.518	Washer brake pedal	1		TE-80015	Bolt Chain guard	1			
118.482	Rear bracket chain guide	1		958.011	Washer rear fender	2		TE-80018	Bolt rear fender	2			
118.488	Front bracket chain guide	1		992.121	Bushing brake shaft	2		TL-60012	Bolt shell and seat	6			
118.507	Washer handlebar bolt	4		992.141	Engine mounting bolt	1							
118700 (*)	Fender front	1		992.301 M	Rear brake lever assembly	1							

(*) When ordering these parts, specify the color

EDITION				
1				
12-70				

EDITION			
1			
12-70			

FRAME

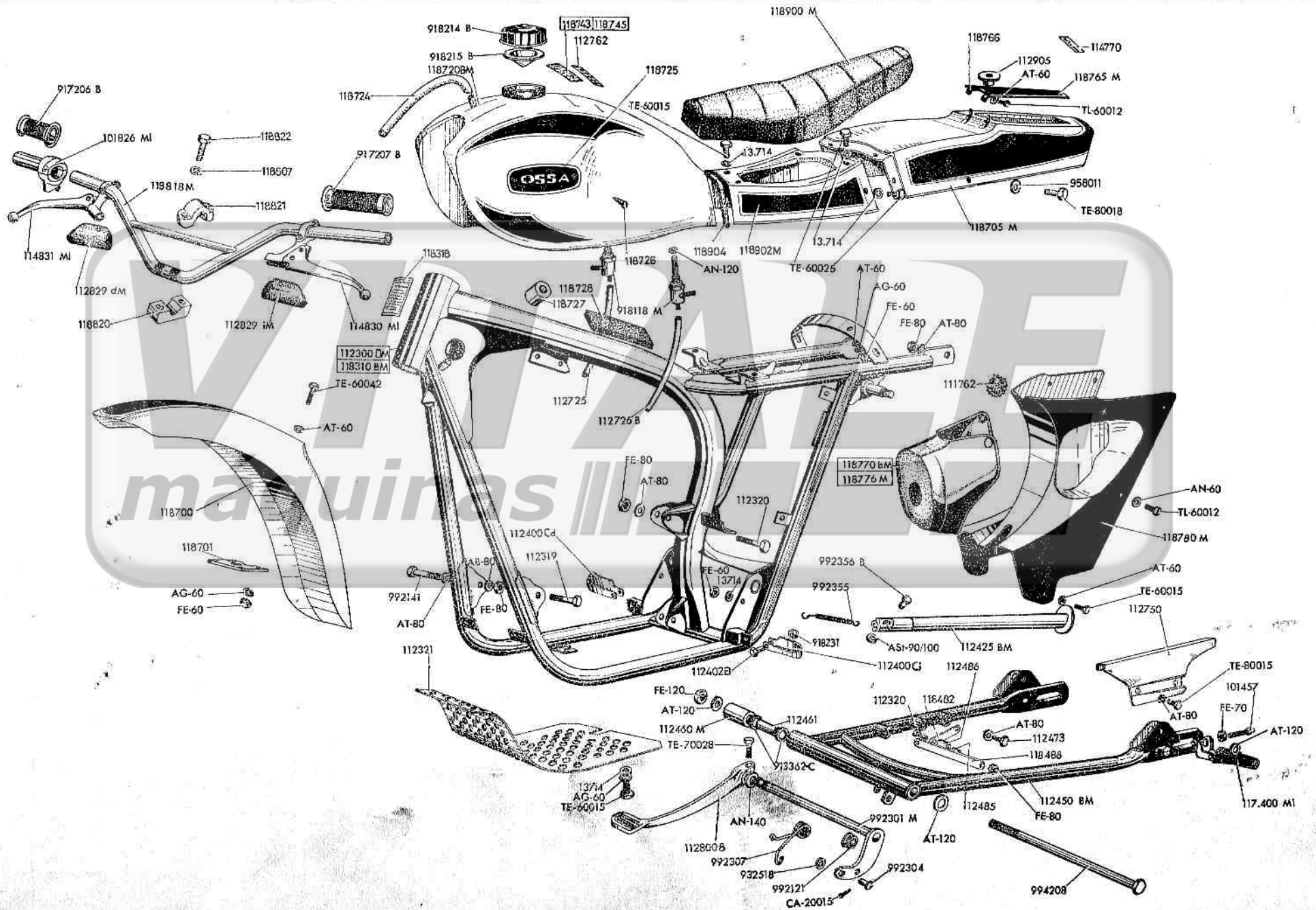

ENGINE

1nd. LIST

Part Number	DESCRIPTION	Quant.	Valid from unit n°	Part Number	DESCRIPTION	Quant.	Valid from unit n°	Part Number	DESCRIPTION	Quant.	Valid from unit n°
33.176 I-II-IV	Shim washer lay shaft			911.139 II-IV-X	Shim washer			991515 BM	Clutch arm assembly	1	
50.404 I-II-IV-X	Shim washer lay shaft			911.218	Spring selector	1		991516 MI	Primary chain	1	
50.559	Washer stop bolt kick	1		911.246	Rubber footshift lever	1		991518	Bushing	1	
101.003 BMI	Piston assembly	1		911.514 B	Slotted nut clutch spring	5		991602 BM	Clutch cover	1	
101.003 BMI S-20	Piston assembly 1st oversize	1		911.604	Drain plug	4		991605	Locating dowel engine case	3	
101.003 BMI S-40	Piston assembly 2nd oversize	1		911.609 C	Locating dowel	4		991606	Gasket center case	1	
101.003 BMI S-60	Piston assembly 3rd oversize	1		911.611	Bolt engine case	14		991607	Gasket primary case	1	
101.003 B	Piston	1		911.614	Screw	6		991608	Anchor pin	1	
101.003 B S-20	Piston 1st oversize	1		911.617	Gasket drain plug	1		991609	Inspection cover	1	
101.003 B S-40	Piston 2nd oversize	1		913.313	Nut clutch hub	1		991610	Gasket, inspection cover	1	
101.003 B S-60	Piston 3rd oversize	1		921.111	Shim washer main shaft 0,05			991611	Grommet rubber	1	
101.005	Wristpin	1		921.112	Shim washer main shaft 0,1			991612 B	Tube breather	1	
101.008	Head gasket	1		921.113	Shim washer main shaft 0,2			991614	Screw engine cover	1	
101.009	Gasket cylinder	1		921.617	Washer	1		991615	Screw engine cover primary side	1	
101.019	Stop bolt kick	1		941.205	Circlip	3		991700	Kickstarter driving gear	1	
101.020 BM	Engine case assembly	1		941.209	Spacer countershaft sprocket	1		991701	Ratchet kickstarter	1	
111.017	Stud carburettor	2		941.212	Washer countershaft sprocket	1		991702 B	Kickstarter shaft	1	
111.019	Nut, intake manifold	2		942.167	Nut stop bolt	1		991703	Kickstarter spring	1	
111.076	Thrust washer	1		964.210	Washer	1		991704	Washer kickstarter spring	2	
111.077	Spacer	1		991.105 M	Rod brg. cage	1		991706	Circlip kickstarter spring	1	
111.078 MI	Needle brg.	1		991.107 B	Crankshaft pin	1		991707	Stop kickstarter spring	1	
111.080 M	Clutch hub assembly	1		991.109 B	Piston circlip	2		991708	Spring kickstarter engage	1	
111.081	Clutch plate inner	1		991.110 B	Flywheel clutch side	1		991709	Thrust washer kickstarter shaft	1	
111.082 M	Clutch plate outer	1		991.111 B	Flywheel maneto side	1		991710	Thrust washer kickstarter gear	1	
111.083 M	Clutch hub assembly	1		991.112	Engine sprocket	4		991713	Spacer ring	1	
111.085	Cup clutch spring	5		991.116	Carburettor stud.	1		991717	Spring lever pin	1	
111.086	Clutch spring	5		991.118	Cylinder head stud.	4		991718	Pin kick lever	1	
112.018	Gasket manifold	1		991.119	Shaft cush drive	1					
112.105	Spacer	1		991.120	Coupling cush drive	1					
112.113	Sprocket	1		991.121	Stop spring	1					
112.114 B	Gear drive	1		991.122	Spring cush drive	1					
112.115	Spacer	2		991.123	Allen nut, cush drive	1					
112.116 M	Bearing assembly	2		991.139 II-IV-X	Shim washer						
112.118 B	Pedal shift	1		991.140	Right main brg.	1					
112.180 BMI	Kickstarter lever assembly	1		991.141	Left main brg.	1					
112.180 B	Kickstarter lever	1		991.200	Main shaft	1					
112.181 B	Support lever	1		991.201	Gear 2nd and 3rd	1		AB-80	Spring washer engine case	1	
112.182	Support kick lever ring	1		991206 B	Lay shaft	1		ACI-60	Washer oil level screw	1	
112.183	Spring washer lever	1		991207 B	Gear 1st lay shaft	1		AF-150	Washer magneto	1	
114.002 B	Cylinder liner	1		991208 B	Gear	1		AG-60	Lock washer clutch arm, inspection cover	7	
114.004	Piston ring oversize	2		991211	Selector fork	1		AG-120	Washer	1	
114.004 S-20	Piston ring 1st oversize	2		991214	Nut countershaft sprocket	1		AG-160	Washer cush drive hub	1	
114.004 S-40	Piston ring 2nd oversize	2		991215	Spring stop selector	2		AN-120	Flat washer	1	
114.004 S-60	Piston ring 3rd oversize	2		991216	Oil seal	1		ASe-100	Snap, ring fork shaft	2	
114.005 MI	Connecting rod assembly	1		991217	Washer lay shaft	3		ASe-180	Snap, ring selector and kickstarter	2	
114.005	Connecting rod	1		991219	Thrust washer	1		AT-60	Clutch arm washer	5	
114.008	Cage big end bearing	1		991221	Shifting fork shaft	1		AT-70	Carburettor mounting washer	2	
114.009	Roller	14		991222	Shifting fork 1st and 3rd	1		AT-80	Washer head and engine cases	5	
114.010 BM	Crankshaft assembly	1		991223	Shifting fork 2nd and 4th	1		B-555	Clutch rod ball	1	
114.012	Gasket carburettor	1		991224 M	Selector body assembly	1		CA-10015	Clutch bolt cotter pin	5	
114.020 MI	Spark plug	1		991226	Washer	2		CE-30022	Kick support pin	1	
114.081	Nut magneto flywheel	1		991227 BM	Selector shaft assembly	1		FE-60	Clutch arm nut	1	
118.016	Spacer carburettor mount	1		991228	Spring selector shaft	1		FE-80	Nut clutch and engine	2	
118.041 MI	Engine assembly	1		991229	Guide selector	1		KC-17-47-14	Gearbox bearing	1	
118.041 M S-20	Cylinder assembly 1st oversize	1		991231	Anchor pin selector	1		KC-25-52-15	Gearbox bearing	1	
118.041 M	Cylinder assembly	1		991232	Spring	1		SG-12-22-5-DL	Oil seal	1	
118.042	Cylinder head	1		991234	Washer selector	1		SG-25-42-8-DL	Oil seal	2	
118.043 MI	Carburettor	1		991235	Circlip selector shaft	1		SG-29-40-7-DL	Oil seal	1	
118.068	Compression release plug	1		991237	Washer selector shaft spring	1		SO-178-26	=O= ring kickstarter	1	
118.069	Compression release gasket	1		991502	Clutch plate	5		TE-60020	Bolt gear lever	1	
118.087 MI	Magneto assembly	1		991503 CM	Clutch plate	5		TE-70025	Bolt kickstarter lever	1	
118.125	Dust cover selector shaft	1		991511	Clutch rod	2		TE-80040	Engine bolt	1	
118.203	Cover magneto side	1		991512	Plunger clutch cam	1		TL-50015	Screw magneto back-plate	3	
911.131	Nut cylinder head	4		991513	Screw, clutch adjusting	1		TL-60012	Clutch cover and oil level bolt	3	
911.135	Nut carburettor mount	4		991514	Cam, clutch	1		TS-60022	Engine case bolt	2	
								XR-30013	Magneto key	1	

COMMON PARTS

EDITION

1					
12-70					

EDITION			
1			
12-70			

ENGINE

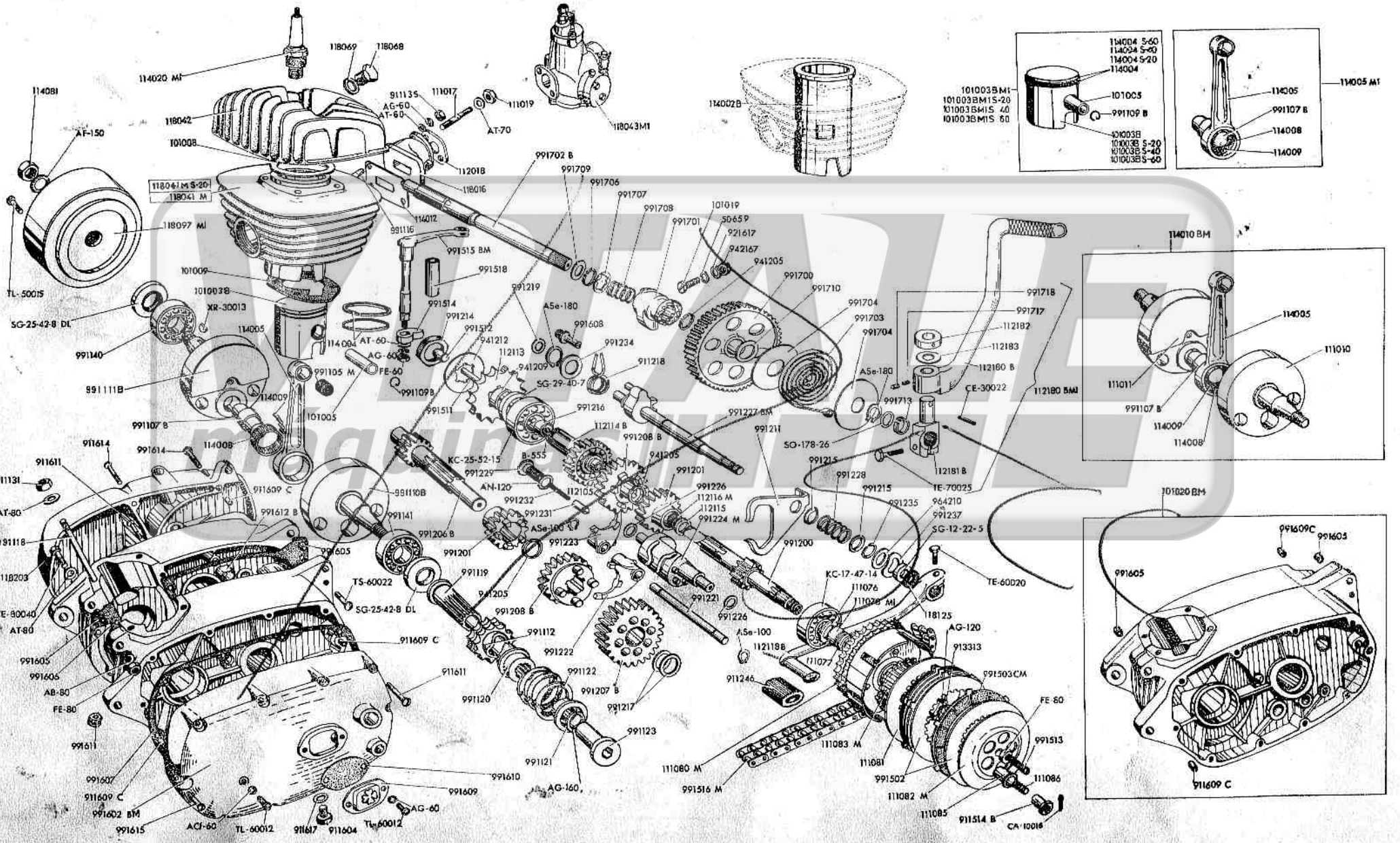

MODEL
175 AE-70

ELECTRICAL ASSEMBLY AND EXHAUST COMPONENTS

5th. LIST

Part Number	DESCRIPTION	Quantity	Valid from unit n°	Part Number	DESCRIPTION	Quantity	Valid from unit n°
13714	Washer, regulator and tail light	5		911133	Spark plug cap	1	
111828	Rubber protector	1		917108	Cable stop	1	
112808 MI	Bracket tail light	1		918231	Nut muffler clamp	2	
112812	Mount horn	1		932553	Ring, exhaust nut	2	
112841 M	Throttle cable assembly	1		996008 MI	Junction box	1	
112845 BMI	Speedo cable	1		998207	Cable protector	1	
112857 M	Guide cable	1		998303	Gasket exhaust pipe	1	
112921	Nut exhaust	1					
112946 M	Silentblock exhaust pipe	1					
112947	Spring exhaust pipe	2					
114808 MI	Fuse box	1					
114842 M	Clutch cable assembly	1		919102	Spark plug socket	1	
114846 BMI	H. T. Coil	1		919105	Adjustable wrench 6 mm.	1	
118801 CM	Wiring harness	1		919107	12 mm. socket	1	
118802 CM1	Wiring head light with switch box	1		919108	Pliers	1	
118803 BM	Wiring tail light	1		919109	Tool bag	1	
118804 M	Wiring regulator and battery	1		919110	T. handle	1	
118805	Bracket regulator and battery	1		919113	23 mm. socket	1	
118806	Battery box foam	1					
118807 MI	Regulator	1					
118808 M	Ground wiring tail light	1					
118814 MI	Fuse holder	1					
118815 M	Wiring fuse to battery	1					
118816 BMI	Horn	1		AG-40	Washer, horn mount	2	
118829	Bracket speedometer mount	1		AG-50	Head light bracket and regulator washer	6	
118830 M	Bracket assembly for speedometer	1		AG-60	Washer H. T. coil, tail light bracket and cable guide	5	
118831 MI	Speedometer assembly	1		AT-40	Washer horn	2	
118833 MI	Head light assembly	1		AT-50	Washer regulator	6	
118834 MI	Ignition switch assembly	1		AT-60	Washer H. T. coil, tail light bracket	5	
118836	Mount switch	1		AT-80	Washer exhaust pipe	2	
118838	Head light bracket	2		FE-40	Nut horn mount	2	
118840 MI	High beam indicator	1		FE-50	Nut regulator	6	
118844	Cable guide	1		FE-60	Nut H. T. coil, tail light bracket	5	
118846 M	Front brake cable assembly	1		LE-6-1, 5 Ø 9	Bulb high beam indicator	1	
118847 M	Wiring stop light rear brake	1		SO-746-53	«O» ring speedometer mount	1	
118848 M	Rear brake cable assembly	1		TE-50015	Bolt head light bracket	2	
118851 MI	Front reflector	2		TE-50018	Bolt regulator	4	
118852 MI	Rear reflector	2		TE-60015	Bolt H. T. coil	2	
118925 M	Exhaust assembly	1		TE-60018	Bolt tail light bracket	3	
911132 B	Rubber wiring protector	1		TL-40012	Bolt horn mount	2	
				TL-40024	Bolt «stop» switch	1	

TOOLS

COMMON PARTS

EDITION				
1				
12-70				

EDITION			
1			
12-70			

ELECTRICAL ASSEMBLY AND EXHAUST COMPONENTS

175 AE-70

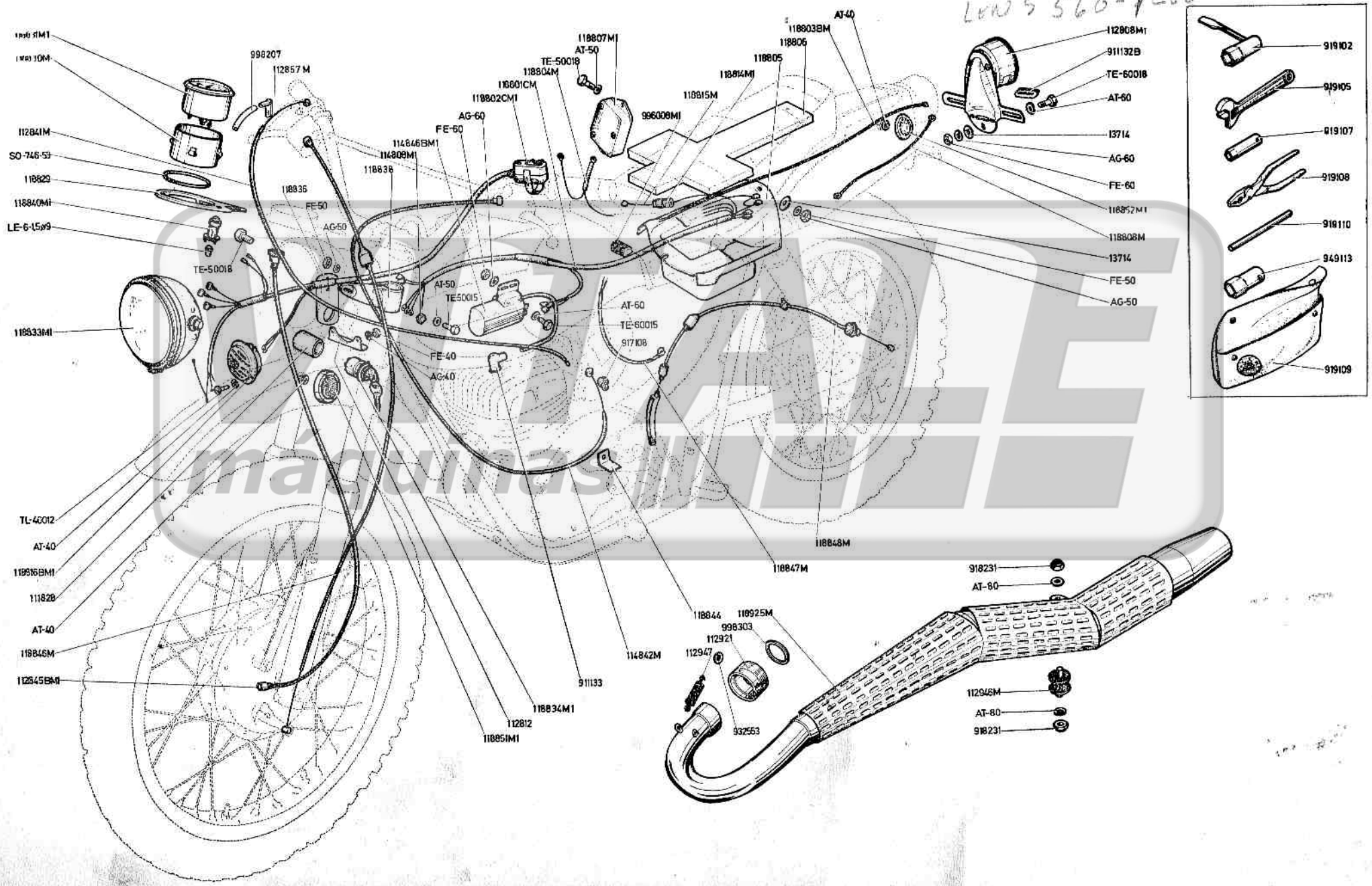

**MODEL
175 AE-70**

WHEELS

4th. LIST

Part Number	DESCRIPTION	Quantity	Valid from unit n ^o r	Part Number	DESCRIPTION	Quantity	Valid from unit n ^o r
112.602-M	Front axle assembly	1		121.659	Washer front axle		
112.604	Nut backing plate shaft	1		121.660	Washer front axle		
112.605	Shaft backing plate	1		914.364	Bolt anchor plate	2	
112.607	Spacer front wheel	1		923.315	Nut backing plate	1	
112.614-MI	Tyre dog	2		943.354	Bolt backing plate	1	
112.619-MI	Front hub assembly 19" with brake	1		943.355-BM	Brake cam assembly	2	
112.621-MI	Front hub assembly 19"	1		943.360	Spring brake shoe	4	
112.632	Innertube	1		943.362	Felt washer	3	
112.633	Rubber innertube	1		943.364-B	Front brake cam	1	
112.638	Spoke nipples	72		943.367	Nut rear axle	2	
112.639	Spokes front Wheel	36		943.372	Washer brake cam	2	
112.641	Front tyre	1		944.355-M	Backing plate	2	
112.646	Reem 21"	1		944.357-M	Bearing cover (for 250AS70 and 175AS70)	1	
112.651-M	Rear axle assembly	1		944.367	Nut rear axle	2	
112.652-D	Rear sprocket	1		993.303	Spacer front wheel	1	
112.653-B	Sprochet maent	1		993.304	Spacer bushing front wheel	1	
112.654-M	Doust cover rear wheel	1		993.305	Aligning washer spacer tube	4	
112.655-B	Bolt rear sprocket	6		993.309	Felt washer	1	
112.658	Innertube	1		993.357-dMI	Front leading brake shoe	2	
112.659	Rubber innertube	1		993.357-tMI	Trailing brake shoe	2	
112.660	Reem	1		994.303	Spacer front wheel	1	
112.664-MI	Tyre dog	2		994.305-B	Lock tab rear sprocket	3	
112.671	Rear tyre	1		994.312-B	Rear brake arm	1	
112.683	Rear sprocket (for 250AS70 and 175AS70)	1		994-313-M	Anchor rear plate wheel	1	
112.685-MI	Secondary chain	1					
112.695-BMI	Secondary chain (for 250AS70 and 175AS70)	1					
114.609-MI	Front hub assembly with brake 21"	1					
114.611-M	Front hub	1					
114.611-MI	Front hub assembly 21"	1		AG-60	Washer anchor arms	2	
114.620	Reem 19"	1		AG-100	Washer backing plate	4	
114.621-B	Spokes for 19" wheel	36		AT-60	Washer front anchor arm	2	
114.659-MI	Rubber innertube			AT-140	Washer front axle	1	
114.661-BM	Rear hub			GR-60	Grease Fitting	2	
114.661-BMI	Rear hub assembly			FE-60	Nut front anchor arm	2	
114.671-B	Spokes rear wheel	36		FE-140	Nut front axle	1	
118.606	Arm. anchor plate	1		KC-15-42-13RS	Wheel bearing with dust cover	4	
118.611-MI	Speedo drive assembly	1		TE-60.022	Bolt, brake arm and anchor arm	4	

EDITION

1				
12-70				

EDITION				
1				
12-70				

WHEELS

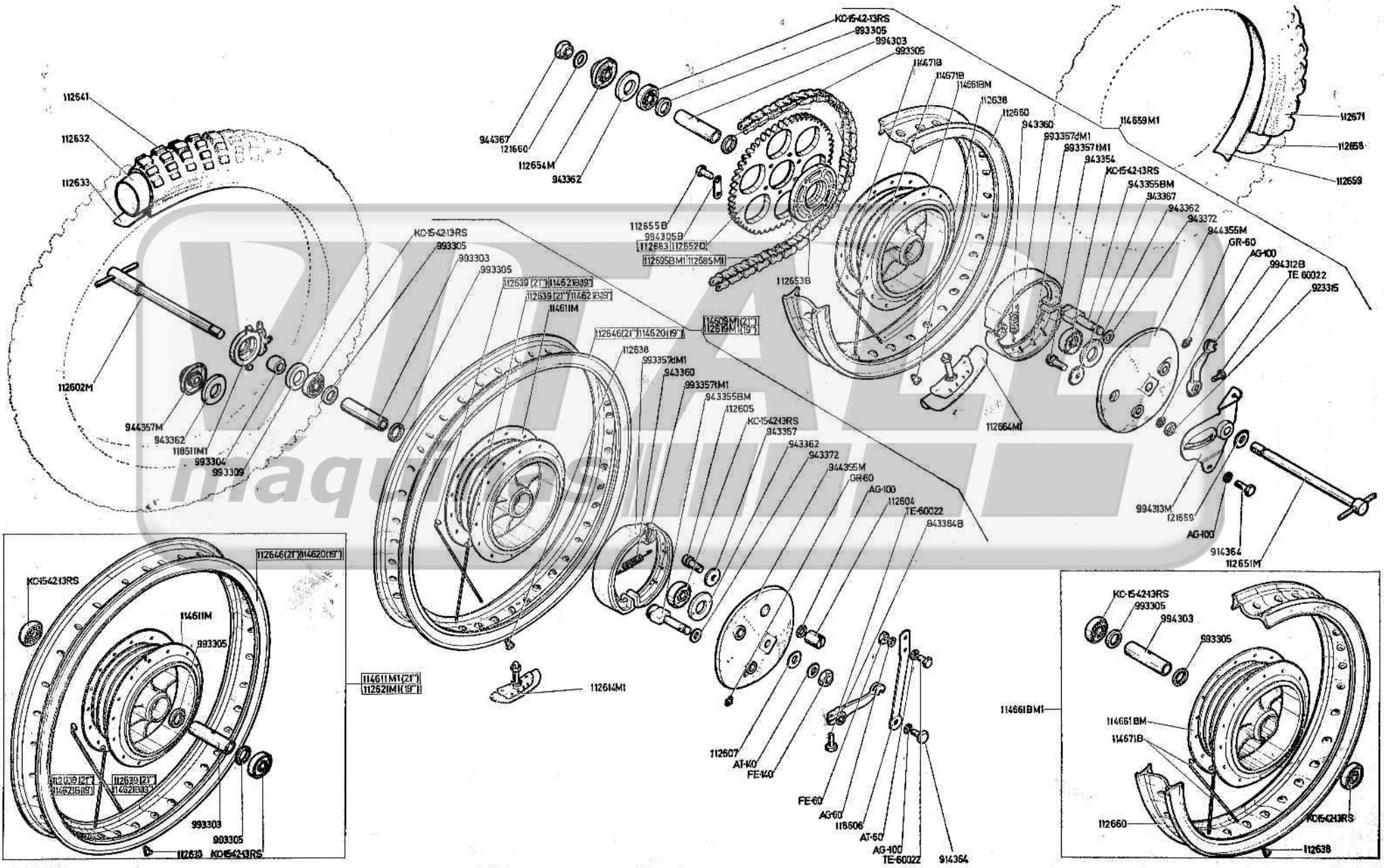

**MODEL
175 AE-70**

SUSPENSION UNITS

3th. LIST

Part Number	DESCRIPTION	Quant.	Valid from unit n°r	Part Number	DESCRIPTION	Quant.	Valid from unit n°r	Part Number	DESCRIPTION	Quant.	Valid from unit n°r
LI-1101-11	Spring seal	2		LI-6215-22	Stanchion tube	2			Shockabsorber assembly (for 175 and 50 AS70)	2	
LI-1101-12A	Guide spring seal	2		LI-6215-47	Spring (for 175-250 AE70 and 250 E70)	2		112.580 BMI	Bolt stanchion tube	8	
LI-1201-13	Spring washer	2						118.505	Bolt steering shaft	1	
LI-1501-15	Oil seal	2		LI-6215-107	Spring stanchion plug	2		118.506	Washer, stanchion tube bolt	8	
LI-1501-16	Adjuster	2		LI-6215-125	Stanchion plug	2		118.507	Washer, steering shaft bolt	1	
LI-1505-37	Silentblock	4		LI-6215-127	Right tank assembly	1		118.508	Top yoke (for 175 and 250 AS70)	1	
LI-1514-011	Regulating bushing	2		LI-6215-129	Left tank assembly	1		118.541	Bottom yoke with stem (for 175 and 250 AS70)	1	
LI-1514-35	Top grip	2		LI-6215-179	Bolt stanchion plug	2		118.542 M	Suspension assembly left for 175 and 250 AS70)	1	
LI-1514-86	Housing for spring	2		LI-6216-47	Spring (for 175 and 250 AS70)	2		118.548 MI	Suspension assembly right (for 175 and 250 AS70)	1	
LI-1515-10	Inner tube	2		LI-8101-15	Bolt M8 x 60	2			Top yoke (for 175-250 AE70 and 250 E70)	1	
LI-1515-26	Guide	2		LI-8101-25	Bolt	2		118.549 MI	Suspension assembly right (for 175-250 AE70 and 250 E70)	1	
LI-1520-47	Spring (for 175 and 250 AS70)	2		LI-8101-27	Allen bolt M8 x 25	2		118.551	Bottom yoke with stem (for 175-250 AE70 and 250 E70)	1	
LI-R-1532	Spare part kit	2		LI-8102-11	Nut M8	2			Suspension assembly right (for 175-250 AE70 and 250 E70)	1	
LI-1532-02	Oil tank	2		LI-8103-10	Polished washer	4		118.552 M	Suspension assembly left (for 175-250 AE70 and 250 E70)	1	
LI-1532-04	Pump assembly	2		LI-8104-10	Spring washer	2			Suspension assembly right (for 175-250 AE70 and 250 E70)	1	
LI-1532-36	Bushing silentblock	2		LI-8104-16	Spring washer	2		118.558 MI	Suspension assembly left (for 175-250 AE70 and 250 E70)	1	
LI-1532-38	Cover	2		LI-8105-12	Bottom nut	2			Shockabsorber assembly (for 175-250 AE70 and 250 E70)	2	
LI-1533-47	Spring (for 175-250 AE70 and 250 E70)	2		LI-8110-10	Security ring I-47	2		118.559 MI	Washer schockabsorber	4	
LI-2204-94	Rings for pump	2		LI-8110-11A	«O» ring 1-30	2					
LI-6204-015	Damper assembly	2		LI-8110-12	Security ring E-16	2		118.575 MI			
LI-6204-020	«O» Ring	2		LI-8111-10	Ball Ø 3,5	2					
LI-6204-07	Valve tube	2		LI-8113-10	Oil seal 35 . 47 . 7	4		914.373			
LI-6204-23	Retaining spring	2		LI-8114-10	Stanchion «O» ring 26 x 32 x 3	2					
LI-6204-29	Valve	2		LI-8114-11	Stanchion «O» ring 12 x 17x2,5	2					
LI-6204-78	Pump	2		LI-8114-21	Washer	2					
LI-6204-98	Cylinder valve mount	2		LI-8115-11	Washer	2					
LI-6204-105	Washer valve	2		LI-8116-10	Washer	2					
LI-6204-110	Washer damper bolt	2		LI-8118-32	Rubber stop	4					
LI-6208-96	Dust cover	2		N-1027	Valve assembly	2					
LI-6215-01	Right tank assembly	1		112.511	Nut steering shaft	1		FE-120	COMMON PARTS		
LI-6215-02	Left tank assembly	1		112.517	Nut steering adjuster	1			Nut shockabsorber	4	
LI-6215-029	Stanchion plug	2		112.518	Felt washer	2		KH-20-47-14	Bearing assembly	2	
				112.519	Dust cover	2		TE-120.045	Bolt, shokabsorber	2	

EDITION

1				
12-70				

EDITION				
1				
12-70				

SUSPENSION UNITS

