

Spare Parts Catalogue

OSSA **stiletto**

250 AS-71 SCRAMBLER

MODEL 250 AS-71		ENGINE								1st. LIST	
Part Number	DESCRIPTION	Quanti.	Valid from unit n ^o	Part Number	DESCRIPTION	Quanti.	Valid from unit n ^o	Part Number	DESCRIPTION	Quanti.	Valid from unit n ^o
11.021 MI	Engine assembly	1		121.117	Washer 1 st. gear	1		991.606	Gasket center case	1	
33.176 I-II-IV	Shim washer lay shaft	—		121-120 M	Needle brg. 1 st. gear	1		991.607	Gasket clutch cover	1	
33.292 I-II-IV	Shim washer lay shaft	—		121.124 M	Selector body assembly	1		991.605	Anchor pin	1	
50.404 I-II-IV-X	Shim washer selector	—		121.125	Dust cover selector shaft	2		991.609	Inspection cover	1	
50.659	Washer, stop bolt kick	1		121.126	Plug selector shaft	1		991.610	Inspection cover gasket	1	
91.019	Stop bolt kick	1		121.127 M	Selector shaft assembly	1		991.611	Grommet rubber	1	
102.005	Wristpin	1		121.128	Washer selector shaft spring	1		991.612 B	Tube breather	1	
111.004 MI	Connecting rod assembly	1		121.130	Main shaft	1		991.615	Screw engine cover primary side	1	
111.004	Connecting rod	1		121.131	Gear 2 nd. main shaft	1		991.701	Ratchet kickstarter	1	
111.009	Cylinder gasket	1		121.132	Gear 3 rd. main shaft	1		991.703	Spring kickstarter	1	
111.010 M	Crankshaft assembly	1		121.134	Gear 5 th. main shaft	1		991.704	Washer kickstarter spring	2	
111.010	Flywheel clutch side	1		121.135	Lay shaft	1		991.705	Circlip kickstarter shaft	1	
111.011	Flywheel magneto side	1		121.137	Gear 1 st. lay shaft	1		991.707	Stop kickstarter spring	1	
111.017	Stud, carburettor	2		121.138	Gear 2 rd. lay shaft	1		991.708	Spring kickstarter engage	1	
111.018	Stud, cylinder head	4		121.139	Gear 3rd. lay shaft	1		991.709	Thrust washer kickstarter shaft	1	
111.019	Nut, intake manifold	2		121.175	Shaft kickstarter	1		991.710	Thrust washer kickstarter gear	1	
111.076	Washer thrust	1		121.176	Kickstarter driving gear	1		991.714 BMI	Kickstarter lever assembly	1	
111.077	Washer spacer	1		121.200 M	Engine cases assembly	1		991.714 B	Kickstarter arm	1	
111.077 M	Needle brg	1		121.202	Clutch cover	1		991.715	Kickstarter lever	1	
111.075	*O* Ring	1		121.203 M	Magneto cover	1		991.716	Stop lever ring	1	
111.080 M	Clutch hub assembly	1		121.206	Bushing	2		991.717	Kick pin spring	1	
111.081	Clutch plate inner	1		911.131	Nut cylinder head	4		991.718	Kick pin	1	
111.082 M	Clutch plate outer	1		911.139 II-IV-X	Shim washer	1					
111.083 M	Clutch hub assembly	1		911.246	Rubber footshift lever	1					
111.085	Cup clutch spring	5		911.514 B	Slotted nut clutch spring	5					
111.086	Clutch spring	5		911.604	Drain plug	1					
112.112	Countershaft sprocket	1		911.609 C	Locating dowel	4					
112.113	Countershaft sprocket z=11	1		911.611	Bolt engine cases	15					
112.116 M	Needle brg. cage 5 th. gear	2		911.614	Screw engine cases	4					
112.140	Countershaft sprocket z=13	1		911.617	Gasket Drain Plug	1					
114.008	Cage big end bearing	1		911.712	Rubber kickstarter	1					
114.009	Roller big end bearing	14		912.604	Washer selector shaft	1					
114.080 MI	Magneto assembly	1		921.111	Shim washer main shaft 0,05	—					
114.081	Nut magneto flywheel	1		921.112	Shim washer main shaft 0,1	—					
118.054	Piston ring	2		921.113	Shim washer main shaft 0,2	—					
118.054 S-20	1st oversize	1		921.617	Washer drain plug	1					
118.054 S-40	2nd oversize	1		941.205	Circlip	5					
118.054 S-60	3rd oversize	1		941.209	Spacer countershaft sprocket	1		AB-80	Spring washer engine case	1	
118.058	Gasket cylinder head	1		941.212	Washer countershaft sprocket	1		ACF-60	Washer oil level screw	1	
118.063	Cylinder sleeve	1		942.167	Nut stop bolt	1		AF-150	Washer magneto	1	
118.064 MI	Piston assembly	1		991.105 M	Rod brg. cage	1		AC-60	Lock washer clutch arm, inspection cover	3	
118.064 S-20 MI	1st oversize	1		991.107 B	Crankshaft pin	1		AG-160	Washer cush drive, hub	2	
118.064 S-40 MI	2nd oversize	1		991.109 B	Piston circlip	2		AN-120	Flat washer	1	
118.064 S-60 MI	3rd oversize	1		991.112	Engine sprocket	1		ASE-100	Snap ring, fork shaft	2	
118.064	Piston	1		991.119	Shaft cush drive	1		ASE-140	Snap ring selector shaft	1	
118.054 S-20	1st oversize	1		991.120	Coupling cush drive	1		ASE-180	Snap ring selector and kickstarter	2	
118.054 S-40	2nd oversize	1		991.121	Stop spring	1		AT-60	Clutch arm washer	1	
118.054 S-60	3rd oversize	1		991.122	Spring cush drive	1		AT-70	Carburettor mounting washer	2	
118.068	Compression release plug	1		991.123	Allen nut cush drive	1		AT-80	Washer head and engine case	5	
118.069	Compression release gasket	1		991.139 II-IV-X	Shim washer	—		B-555	Clutch rod ball	1	
118.086 MI	Carburettor	1		991.140	Right main brg.	1		CA-10.015	Clutch bolt cotter pin	5	
118.087	Carburettor manifold spacer	1		991.141	Left main brg.	1		CE-30.014	Cotter pin kickstarter	1	
121.005	Stud, protection tube	4		991.211	Selector fork	1		FE-60	Clutch arm nut	1	
121.021 M	Cylinder assembly	1		991.214	Nut countershaft sprocket	1		FE-80	Nut clutch and engine case	2	
121.021 MS-20	Cylinder assembly 1st oversize	1		991.215	Spring stop selector	2		KC-17-47-14	Gearbox bearing	1	
121.023 MI	Spark plug	1		991.216	Oil seal	1		KC-25-52-15	Gearbox bearing	1	
121.027	Cylinder head	1		991.228	Spring selector shaft	1		SG-25-47-8 DL	Oil seal	2	
121.077	Nut clutch hub	1		991.229	Guide selector	1		SG-29-40-7 DL	Oil seal	1	
121.078	Clutch rod	2		991.231	Anchor pin selector	1		SO-139-26	*O* ring selector shaft	2	
121.079 M	Clutch arm assembly	1		991.232	Spring pin selector	1		SO-178-26	*O* ring kickstarter	1	
121.103	Gear 4 th. main shaft	1		991.234	Washer selector shaft	1		TE. 60.020	Bolt gear lever	1	
121.105	Dog wheel 4 th. and 5 th. gear	1		991.235	Retaining ring	1		TE. 70.022	Bolt kickstarter lever	1	
121.110	Shifting fork 1 st. and 3 rd.	1		991.502	Clutch plate	5		TE. 80.040	Engine bolt	1	
121.111	Shifting fork 2 nd.	1		991.503 CM	Clutch plate	5		TL. 50.015	Screw, magneto back plate	3	
121.112	Shifting fork 4 th. and 5 th.	1		991.512	Plunger clutch arm	1		TL. 60.012	Clutch, cover and oil level bolt	3	
121.113	Spacer 5 th. gear	1		991.513	Clutch regulating screw	1		TS. 60.022	Engine case bolt	2	
121.114	Shifting fork shaft	1		991.514	Clutch cam	1		TS. 60.075	Bolt magneto cover	2	
121.115	Spring selector	1		991.516 CM	Chain primary	1		TS. 60.080	Bolt magneto cover	1	
121.116	Footshift lever	1		991.605	Locating dowel engine cases	1		XR. 30.013	Magneto key	1	

EDITION

1			113700
9-70			

**MODEL
250 AS-71**

FRAME

2nd. LIST

Part Number	DESCRIPTION	Quantity	Valid from unit n°	Part Number	DESCRIPTION	Quantity	Valid from unit n°
13.714	Washer, engine protector, rear fender, gas tank	12		118.818 M	Handlebar	1	
101.457	Bolt, rear wheel adjuster	2		118.820	Handlebar mount	2	
112.400 Cd	Right front footpeg	1		118.821	Handlebar clamp	2	
112.400 Ci	Left front footpeg	1		118.822	Handlebar bolt	4	
112.402 B	Footpeg shaft	2		118.845	Spark plug labbel (Handlebar)	1	
112.432 M	Side stand	1		121.320	Bolt engine	2	
112.471	Swing arm axle	1		121.345 M	Frame assembly	1	
112.472	Bushing swing arm	2		121.452 M	Swing arm assembly	1	
112.473	Bolt chain guide	2		121.483	Bolt chain guide	1	
112.474	Bolt swing arm	2		121.720	Clip fuel line	4	
112.485	Spacer chain guide	1		121.769 M	Shell right	1	
112.486	Pin chain guide	1		121.827 Ml	Twist grip assembly	1	
112.492	Rubber plug swing arm	1		912.604	Washer brake pedal	1	
112.715 CM (*)	Fender rear	1		917.206 B	Rubber grip throttle	1	
112.720 CM (*)	Gas tank	1		917.207 B	Rubber grip handlebar	1	
112.724	Rubber washer tank mount	2		918.118 M	Petcock assembly	2	
112.725	Fuel line right	1		918.214 B	Gas cap	1	
112.726 B	Fuel line left	1		918.215 B	Rubber seal	1	
112.741	Bracket number plate	1		918.231	Footpeg nut	2	
112.742	Rubber «O» ring	1		932.518	Washer brake pedal	1	
112.749 (*)	Number plate	1		958.011	Washer rear fender	2	
112.750	Chain guard	1		992.141	Engine mounting bolt	2	
112.761	Decal «Scrambler»	1		992.304	Clevis pin rear brake	1	
112.770 B (*)	Shell left	1					
112.771 M	Air filter	1					
112.774 B (*)	Filter cover	1					
112.775	Tube filter (for 250-AS)	1					
112.776 BMI	Clamp carburettor and filter	2					
112.777	Nut air filter	1					
112.821	Brake pedal return spring	1		AB-80	Spring washer	2	
112.829 dM	Cable dust protector right	1		AB-100	Spring washer	2	
112.829 IM	Cable dust protector left	1		AF-120	Washer swing arm	2	
112.833 BM	Brake lever assembly	1		AG-60	Washer fenders and number plate	10	
112.900 BM	Seat	1		AG-80	Washer chain guide	1	
112.903	Seat mount	1		AN-60	Washer shell	5	
112.905	Seat nut	1		AN-120	Washer petcock	2	
114.830 MI	Clutch lever assembly	1		AT-60	Washer fender, shell, number plate and seat	12	
114.831 MI	Brake lever assembly	1		AT-80	Washer engine, chain guide, fenders and chain guard	9	
118.319	Specifications labbel (Frame)	1		AT-100	Washer rear engine mount	2	
118.488	Front bracket chain guide	1		CA-20.015	Cotter pin brake cable	1	
118.489	Rear bracket chain guide	1		CA-25.025	Cotter pin brake pedal	1	
118.507	Washer handlebar bolt	4		FE-60	Nut fenders, shell, air filter and number plate	13	
118.701	Mount front fender	1		FE-70	Nut adjusting bolt	2	
118.704 (*)	Front fender	1		FE-80	Nut engine mount, fender rear	5	
118.716	Decal «Stiletto»	1		FE-100	Nut rear engine mount	2	
118.724	Tube breather	1		TE-60.015	Bolt, gas tank, shell and number plate	7	
118.725	Tank badge «OSSA»	2		TE-60.025	Bolt rear fender	4	
118.726	Bolt, tank badge	4		TE-60.042	Bolt front fender	4	
118.743	Decal «250 cc».	1		TE-80.015	Bolt chain guide	1	
118.745	Decal «175 cc»	1		TE-80.018	Bolt rear fender	2	
118.775	Tube filter (for 175-AS)	1		TL-60.012	Bolt shell and seat	6	

COMMON PARTS

(*) When ordering these parts, specify the color

EDITION

1				118700
9-70				

EDITION			
1			118700
9-70			

FRAME

250 AS-71

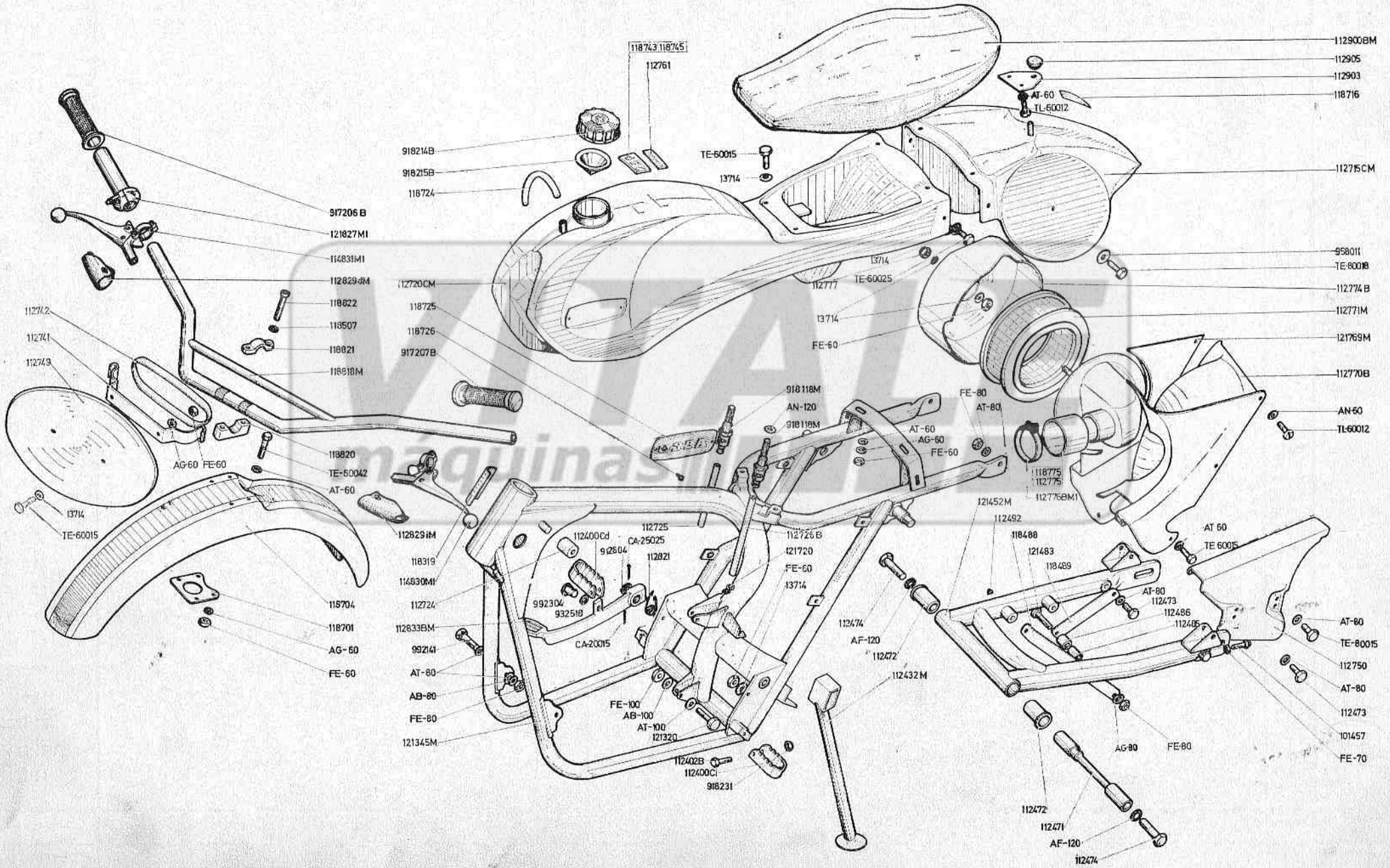

MODEL
250 AS-71

SUSPENSION UNITS

3th. LIST

Part Number	DESCRIPTION	Quantity	Valid from unit n°r	Part Number	DESCRIPTION	Quantity	Valid from unit n°r
LI-1101-11	Spring seal	2		LI-8110-11A	«O» ring 1-30	2	
LI-1101-12A	Guide spring seal	2		LI-8114-10	Stanchion «O» ring 26 x 32 x 3	2	
LI-1501-16	Adjuster	2		LI-8114-11	Stanchion «O» ring 12 x 17 x 2,5	2	
LI-1514-011	Regulating bushing	2		112.511	Nut steering shaft	1	
LI-1514-35	Top grip	2		112.517	Nut steering adjuster	1	
LI-1514-86	Housing for spring	2		112.518	Felt washer	2	
LI-1515-10	Inner tube	2		112.519	Dust cover	2	
LI-1515-26	Guide	2		112.580 BMI	Shockabsorber assembly (for 175 and 250 AS71)	2	
LI-1520-47	Spring (for 175 and 250 AS71)	2		118.505	Bolt stanchion tube	8	
LI-R-1532	Spare part kit	2		118.506	Bolt steering shaft	1	
LI-1532-02	Oil tank	2		118.507	Washer, stanchion tube bolt	8	
LI-1532-38	Cover	2		118.503	Washer, steering shaft bolt	1	
LI-1533-47	Spring (for 175-250 AE71 and 250 E71)	2		118.541	Top yoke (for 175 and 250 AS71)	1	
LI-6204-015	Damper assembly	2		118.542 M	Bottom yoke with stem (for 175 and 250 AS71)	1	
LI-6204-110	Washer damper bolt	2		118.548 MI	Suspension assembly left (for 175 and 250 AS71)	1	
LI-6208-96	Dust cover	2		118.549 MI	Suspension assembly right (for 175 and 250 AS71)	1	
LI-6215-01	Right tank assembly	1		118.551	Top yoke (for 175-250 AE71 and 250 E71)	1	
LI-6215-02	Left tank assembly	1		118.552 M	Bottom yoke with stem (for 175-250 AE71 and 250 E71)	1	
LI-6215-029	Stanchion plug	2		118.558 MI	Suspension assembly right (for 175-250 AE71 and 250 E71)	1	
LI-6215-22	Stanchion tube	2		118.559 MI	Suspension assembly left (for 175-250 AE71 and 250 E71)	1	
LI-6215-47	Spring (for 175-250 AE71 and 250 E71)	2		118.575 MI	Shockabsorber assembly (for 175-250 AE71 and 250 E71)	2	
LI-6216-47	Spring (for 175 and 250 AS-71)	2		914.373	Washer shockabsorber	4	
LI-8101-15	Bolt M8 x 60	2					
LI-8101-27	Allen bolt M8 x 25	2					
LI-8102-11	Nut M8	2					
LI-8103-10	Polished washer	4					
LI-8104-10	Spring washer	2		FE-120	Nut shockabsorber	4	
LI-8104-16	Spring washer	2		KH-20-47-14	Bearing assembly	2	
LI-8105-12	Bottom nut	2		TE-120.045	Bolt, shokabsorber	2	
					COMMON PARTS		

EDITION

1				118700
9-70				

EDITION			
1			118700
9-70			

SUSPENSION UNITS

250 AS-71

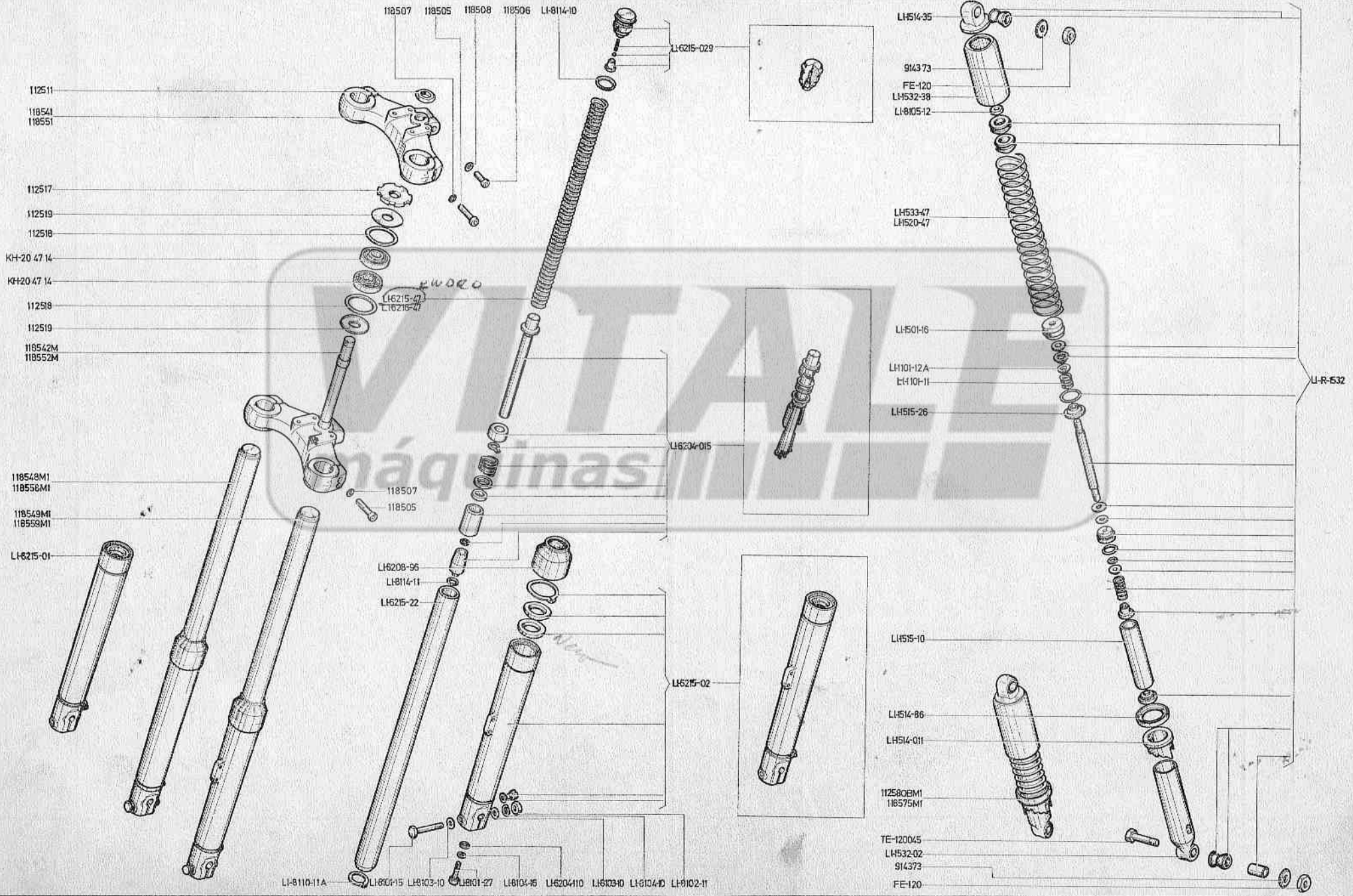

MODEL
250 AS-71

WHEELS

4th. LIST

Part Number	DESCRIPTION	Quantity	Valid from unit n°	Part Number	DESCRIPTION	Quantity	Valid from unit n°
101.661 B	Bolt rear sprocket	8		914.364	Bolt anchor plate	2	
112.602 M	Front axle assembly	1		923.315	Nut backing plate	1	
112.604	Nut backing plate shaft	1		943.354	Bolt backing plate	1	
112.605	Shaft backing plate	1		943.355 BM	Brake cam assembly	2	
112.607	Spacer front wheel	1		943.360	Spring brake choe	4	
112.614 MI	Tyre dog	2		943.362	Felt washer	4	
112.619 MI	Front hub assembly 19" with brake	1		943.364 B	Front brake am	1	
112.621 MI	Front hub assembly 19"	1		943.367	Thrust washer	2	
112.632	Innertube	1		943.372	Washer brake cam	2	
112.633	Rubber innertube	1		944.355 M	Backing plate	2	
112.638	Spoke nipples	72		944.357 M	Bearing cover (for 175-250AS)	1	
112.641	Front tyre	1		944.367	Nut rear axle	1	
112.646	Reem 21"	1		993.303	Spacer front wheel	1	
112.651 M	Rear axle assembly	1		993.304	Spacer busting front wheel (175-250AE-250E)	1	
112.658	Innertube	1		993.305	Aligning washer spacer tube	4	
112.659	Rubber innertube	1		993.309	Felt washer	1	
112.660	Reem	1		993.357 dMI	Front leading brake shoe	2	
112.664 MI	Tyre dog	2		993.357 tMI	Trailing brake shoe	2	
112.671	Rear tyre	1		994.303	Spacer tube rear wheel	1	
112.695 BM	Secondary chain (for 250-175 AS)	1		994.312 B	Rear brake arm	1	
114.609 MI	Front hub assembly with brake 21"	1		994.313M	Anchor plate rear wheel	1	
114.611 MI	Front hub	1					
114.620	Reem 19"	1					
114.621	Spokes for 19" wheel	36					
118.606	Arm anchor plate	1					
118.611 MI	Speedo drive assembly (for 175-250 AE-250 E)	1					
121.603	Spokes (innerside) front wheel	18					
121.604	Spokes (outerside) front wheel	18					
121.648 MI	Rear hub assembly with brake	1					
121.649 MI	Rear hub assembly	1					
121.650 M	Rear hub	1					
121.651	Rear sprocket (for 175-250 AE-250E)	1		AG-60	Washer anchor arm	2	
121.652	Rear sprocket (for 175-250AS)	1		AG-80	Washer rear sprocket	8	
121.653	Rear sprocket (for 175-250AS) z=57	1		AG-100	Washer backing plate	4	
121.655	Spokes (innerside) rear wheel	18		AT-60	Washer Front anchor arm	2	
121.656	Spokes (outerside) rear wheel	18		AT-140	Washer front axle	1	
121.657 M	Bearing cover rear wheel	1		GR-60	Grease Fitting	2	
121.658 MI	Scndary chain (for 175-250AE-250E)	1		FE-60	Nut front anchor arm	2	
121.659	Left washer rear axle	1		FE-140	Nut front axle	1	
121.660	Right washer rear axle	1		KC-15-42-13RS	Wheel bearing with dust cover	4	
				TE-60022	Bolt, brake arm and anchor arm	4	

COMMON PARTS

EDITION

1				118700
9-70				

1				118700
9-70				

WHEELS

250 AS-71

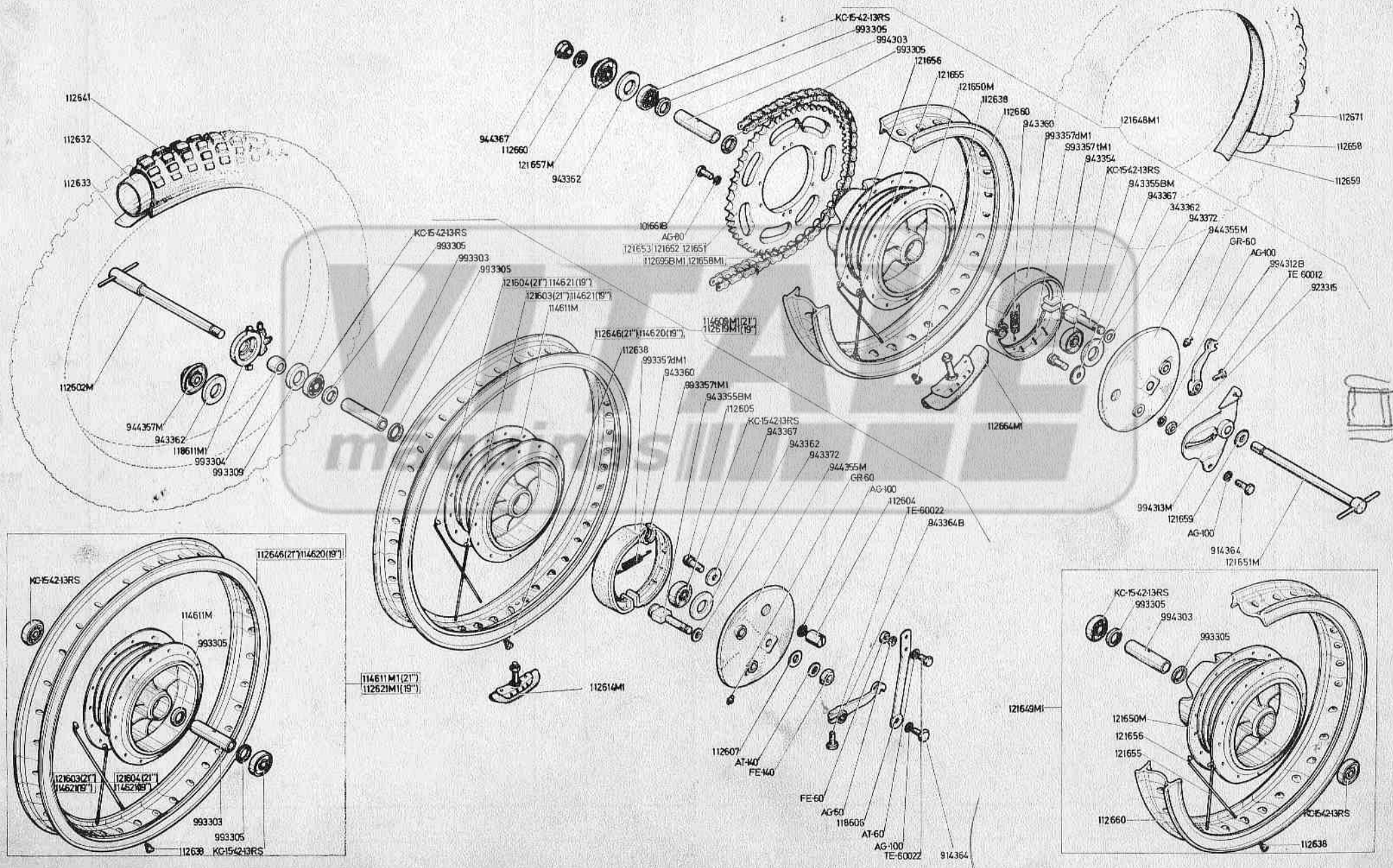

MODEL
250 AS-71

ELECTRICAL ASSEMBLY AND EXHAUST COMPONENTS

5th. LIST

Part Number	DESCRIPTION	Quantity	Valid from unit n°r	Part Number	DESCRIPTION	Quantity	Valid from unit n°r
112.855	Rubber ring rear brake	2			TOOLS Spark plug socket Adjustable wrench 12 mm. socket Pliers Tool bag T. Handle 23 mm. socket		
112.860 BM	Rear cable assembly	1					
112.946 M	Exhaust silent block	2		919.102			
112.947	Spring exhaust mount	2		919.105			
114.840 M	Front cable assembly	1		919.107			
114.846 BM	H.T. coil	1		919.108			
118.844 B	Cable guide	1		919.109			
121.803	Spark plug cap	1		919.110			
121.804	Spring spark plug cap	1		949.113			
121.841 M	Throttle cable assembly	1					
121842 M	Clutch cable assembly	1					
121.921	Exhaust nut	1					
121.923 M	Expansion chamber (for 175 AS)	1					
121.945 M	Expansion chamber (for 250 AS)	1					
918.231	Exhaust nut mount	4					
996.028 M	Junction block	1					
998.303 B	Gasket exhaust nut	1					
COMMON PARTS							
AG-60	Washer H.T. coil, cable guide	3					
AG-120	Washer exhaust spring	2					
AT-60	Washer H.T. coil	2					
AT-80	Washer expansion chamber	4					
FE-60	Nut H.T. coil	2					
TE-60010	Bolt cable guide	1					
TE-60015	Bolt H.T. coil	2					



EDITION				
1				118700
9-70				

EDITION			
1			118700
9-70			

ELECTRICAL ASSEMBLY AND EXHAUST COMPONENTS

5 SHEET

250 AS-71

